

# User Manual

Version V1.0-20180629

# User Manual For BX Series GNSS Receiver

©2018 Tersus GNSS Inc. All rights reserved.

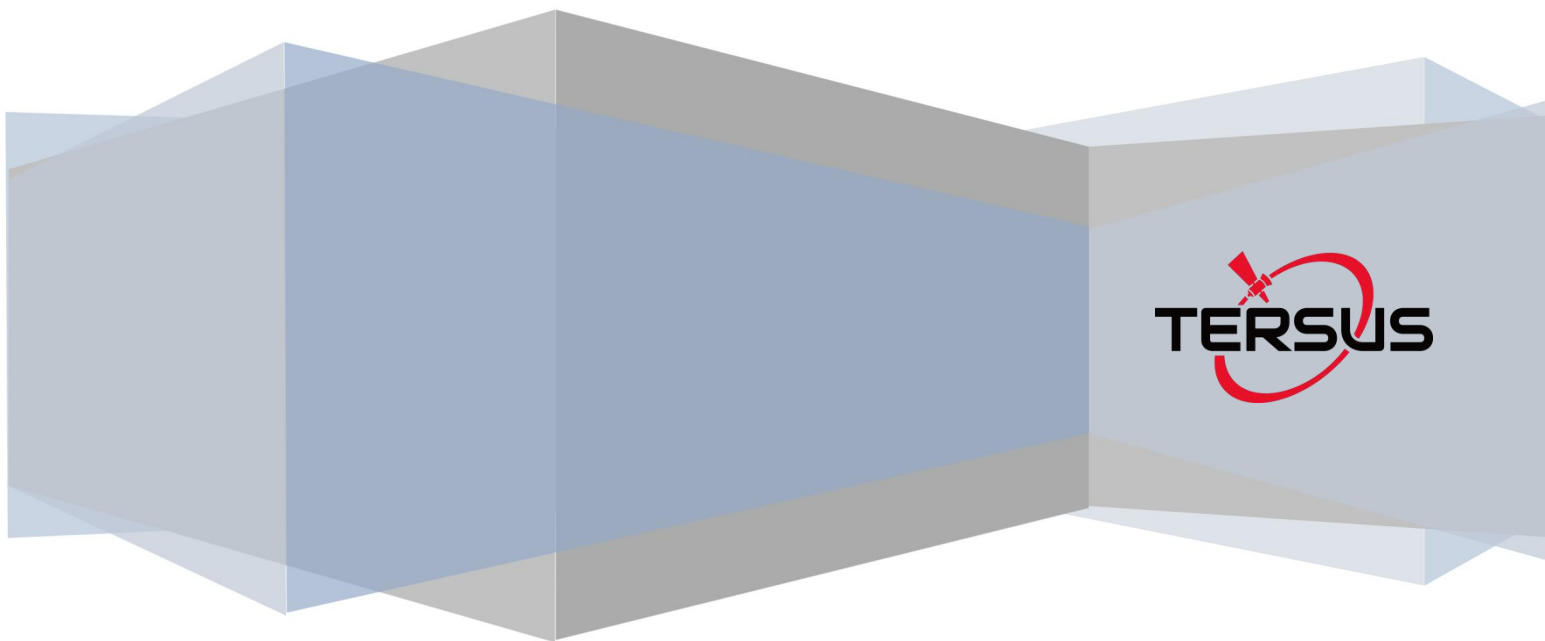

Revision	Description	Date	Owner
1	Issued for Review	2018/06/29	CB

# Table of Content

Notices.....	1
Support.....	3
1. Introduction.....	4
1.1 Overview of BX Series GNSS Receivers.....	4
1.1.1 BX GNSS OEM Boards.....	4
1.1.2 BX GNSS Enclosures.....	4
1.2 Related Documents and Information.....	5
1.2.1 OEM BX306 Board.....	5
1.2.2 OEM BX306Z Board.....	6
1.2.3 OEM BX316D Board.....	8
1.2.4 BX306 Enclosure.....	9
1.2.5 BX316 Enclosure.....	11
1.2.6 BX316R Enclosure.....	12
1.3 BX Receivers System Overview.....	13
1.3.1 BX Series OEM Boards.....	14
1.3.2 BX Enclosures.....	15
1.3.3 Antenna.....	15
1.3.4 Power Supply.....	15
1.3.5 Communication Equipment.....	15
1.3.6 External SD/Internal eMMC Card.....	15
1.3.7 Enable Heading.....	16
2. Installation.....	17
2.1 Shipping Box.....	17
2.2 USB Adapter.....	18
2.3 Selecting a GNSS Antenna.....	19
2.4 Power Supply Requirement.....	20
2.5 OEM Boards Installation Overview.....	20
2.6 Tersus GNSS Center Software.....	21
2.6.1 Auto Base Station List Function.....	23

2.7	Transmitting and Receiving Corrections.....	25
2.8	Heading Output.....	26
3	FW Update and Auth Code.....	27
3.1	Firmware Updates.....	27
3.2	Upgrading FW Using Tersus GNSS Center.....	27
3.3	Auth Code.....	32
4	BX306 Board Technical Specifications.....	33
4.1	Connectors on BX306 board.....	35
4.2	Reference Schematic of the Interface Board.....	36
5.	BX306Z Board Technical Specifications.....	39
5.1	Connectors on BX306Z Board.....	41
6.	BX316D Board Technical Specifications.....	44
6.1	Connectors on BX316D Board.....	46
7.	BX306 Enclosure Technical Specifications.....	48
7.1	20-Pin Cable.....	49
8.	BX316 Enclosure Technical Specifications.....	52
8.1	40-Pin Cable.....	53
9.	BX316R Enclosure Technical Specifications.....	56
10.	Typical Application.....	58
10.1.	Uninstall the Cable from BX306 Enclosure.....	58
10.2.	Connect BX306 to Pixhawk.....	59
10.3.	Connect BX306 to a Radio.....	62
10.3.1	Radio to Receive RTK Corrections.....	63
10.3.2	Radio to Transmit RTK Corrections.....	63
10.3.3	Radio to Transmit the PVT Solutions.....	64
10.4.	Save Data to an External Datalogger.....	64
10.5.	Connect BX306 to an External Bluetooth.....	65
10.5.1	Communicate with NTRIP Client App.....	66
10.6	Communicate with STRSVR Tool.....	68
10.7	Data Collection on Internal eMMC Card.....	70

10.8	Download Files from Internal eMMC Card.....	71
11	Terminology.....	76

## List of Figures

Figure 1 Overview of BX306 Board.....	5
Figure 2 Overview of BX306Z Board.....	6
Figure 3 Overview of BX316D Board.....	8
Figure 4 Overview of BX306 Enclosure.....	9
Figure 5 BX306 Enclosure Panel.....	10
Figure 6 Overview of BX316 Enclosure.....	11
Figure 7 BX316 Enclosure Panel.....	12
Figure 8 Overview of BX316R Enclosure.....	13
Figure 9 System Overview of BX Boards.....	14
Figure 10 Parts in the Kit Package.....	17
Figure 11 USB Adapter.....	18
Figure 12 Device Manager.....	18
Figure 13 Antennas from Tersus.....	19
Figure 14 Config Page of Tersus GNSS Center.....	21
Figure 15 BX306 Enclosure Connected to a Laptop.....	22
Figure 16 Main Windows of Tersus GNSS Center.....	23
Figure 17 Base/Rover Configure.....	25
Figure 18 3.3V Reference Schematic.....	37
Figure 19 5V Reference Schematic.....	37
Figure 20 Reference Schematic for a Serial Port.....	37
Figure 21 Reference Schematic for USB.....	38
Figure 22 Reference Schematic for Ethernet.....	38
Figure 23 Outline of the 20-pin Cable.....	50
Figure 24 Outline of the 40-pin Cable.....	54
Figure 25 Cable is Assembled.....	58
Figure 26 Uninstall the Cable.....	59
Figure 27 Cable between Pixhawk and BX306.....	59
Figure 28 Outline of BX306 Connected to Pixhawk.....	59
Figure 29 Pixhawk Get Position from BX306.....	60
Figure 30 Transfer Cable.....	62
Figure 31 Outline of BX306 Connected to RS05R Radio.....	63
Figure 32 Datalogger DL207.....	64
Figure 33 Outline of BX306 Connected to DL207.....	65
Figure 34 BT120 and the Cable.....	66
Figure 35 Outline of BX306 Connected to BT120.....	66
Figure 36 Download Files from eMMC Card with a Serial Port.....	72
Figure 37 Download Files from eMMC Card with an USB Port.....	72
Figure 38 USB Cable.....	72

## List of Tables

Table 1 The Document / Software Used in This User Manual.....	3
Table 2 Features of BX306 Board.....	5
Table 3 LED Definition of BX306 board.....	6
Table 4 Features of BX306Z Board.....	7
Table 5 LED Definition of BX306Z Board.....	7
Table 6 Features of BX316D Board.....	8
Table 7 LED Definition of BX316D Board.....	9
Table 8 Features of BX306 Enclosure.....	10
Table 9 LED Definition of BX306 Enclosure.....	10
Table 10 Features of BX316 Enclosure.....	11
Table 11 LEDs on BX316 Enclosure Panel.....	12
Table 12 Features of BX316R Enclosure.....	13
Table 13 Input Power Requirements.....	20
Table 14 Definition of the LEDs on Tersus GNSS Center.....	22
Table 15 BX306 Board Performance.....	33
Table 16 Interface Signals Definition.....	35
Table 17 BX306Z Board Performance.....	39
Table 18 Interface Signals Definition.....	41
Table 19 BX306D Board Performance.....	44
Table 20 Interface Signals Definition.....	46
Table 21 BX306 Enclosure Performance.....	48
Table 22 Pin Definition of the 20-pin Cable.....	51
Table 23 BX316 Enclosure Performance.....	52
Table 24 Pin Definition of the 40-pin Cable.....	54
Table 25 BX316R Enclosure Performance.....	56
Table 26 Configure for Pixhawk.....	60
Table 27 Main Steps to Create RTK Base for Pixhawk.....	61
Table 28 Dave Data on eMMC Card Manually.....	71
Table 29 Save Data on eMMC Card Automatically.....	71
Table 30 Detailed Steps to Download Files from eMMC Card.....	73

## Notices

### **FCC Notices**

The BX306 enclosure has been tested and found to comply with the radiated and conducted emission limits for a Class A digital device. The Class A limits are designed to provide reasonable protection against harmful interference in a residential installation.

The BX316 enclosure has been tested and found to comply with the radiated and conducted emission limits for a Class A digital device. The Class A limits are designed to provide reasonable protection against harmful interference in a residential installation.

### **CE Marking**

Tersus Inc. declares that BX306 enclosure and BX316 enclosure are in compliance with the essential requirements (radio performance, electromagnetic compatibility and electrical safety) and other relevant provisions of Directive 1999/5/EC, EMC Directive 2004/108/EC, and the RoHS Recast Directive 2011/65/EU. Therefore the equipment is labeled with the following CE-marking.



The Declaration of Conformity may be obtained from Tersus Inc.



The following notices apply to all Tersus BX series receivers.



Changes or modifications to this equipment not expressly approved by Tersus could void the user's authority to operate this equipment or even has risk to damage the receivers.

## Conventions

The following conventions are used in this manual:



Information that supplements or clarifies text.



A caution that actions, operation or configuration may lead to incorrect or improper use of the hardware.



A warning that actions, operation or configuration may result in regulatory noncompliance, safety issues or equipment damage.

Tersus is providing BX series GNSS receivers with OEM version as well as with enclosure in a metal box. When a board is mentioned, it's OEM version of the receiver, specifically. When enclosure is mentioned, it's receiver version in a box, specifically.

In this manual, all the commands to a receiver are in capital letters, which is just for easy identification, the commands are not case-sensitive.

Table 1 The Document / Software Used in This User Manual

Name	Description	Link
Log & Command document	Document giving all the loggings output from BX series receivers and all the commands to them	<a href="https://www.tersus-gnss.com/document">https://www.tersus-gnss.com/document</a>
Tersus GNSS Center	Graphical tool to communicate with BX series receivers	<a href="https://www.tersus-gnss.com/software">https://www.tersus-gnss.com/software</a>
Tersus Download	A tool to download files on the internal eMMC card to a computer	<a href="https://www.tersus-gnss.com/assets/upload/file/20180608172619305.rar">https://www.tersus-gnss.com/assets/upload/file/20180608172619305.rar</a>
RTKLIB	A free & popularly used Post processing tool	<a href="http://www.rtklib.com/">http://www.rtklib.com/</a>
Mission Planner	A popular Ground Station software	<a href="http://firmware.ardupilot.org/Tools/MissionPlanner/MissionPlanner-latest.msi">http://firmware.ardupilot.org/Tools/MissionPlanner/MissionPlanner-latest.msi</a>

## Support

If you have a problem and cannot find the information you need in the product documentation, request technical support using the Tersus website at <https://www.tersus-gnss.com/>, or mail to [support@tersus-gnss.com](mailto:support@tersus-gnss.com).

# 1. Introduction

---

## 1.1 Overview of BX Series GNSS Receivers

BX series GNSS receivers are cost-efficient GNSS RTK board for cm-level positioning, which can be used for real-time RTK positioning as well as raw data collection for post-processing application. BX receivers are supporting existing and planned GPS, BDS and GLONASS signals. Both the cards and the enclosures are designed for the flexibility of integration and configuration.

BX series receivers are delivered with OEM cards as well as in enclosures. For further information about BX receivers, refer to <https://www.tersus-gnss.com/> for more detail.

### 1.1.1 BX GNSS OEM Boards

OEM BX306 board - refer to section 1.2.1 for details

OEM BX306Z board - refer to section 1.2.2 for details

OEM BD316D board - refer to section 1.2.3 for details

### 1.1.2 BX GNSS Enclosures

BX306 enclosure – refer to section 1.2.4 for details

BX316 enclosure - refer to section 1.2.5 for details

BX316R enclosure - refer to section 1.2.6 for details

## 1.2 Related Documents and Information

### 1.2.1 OEM BX306 Board

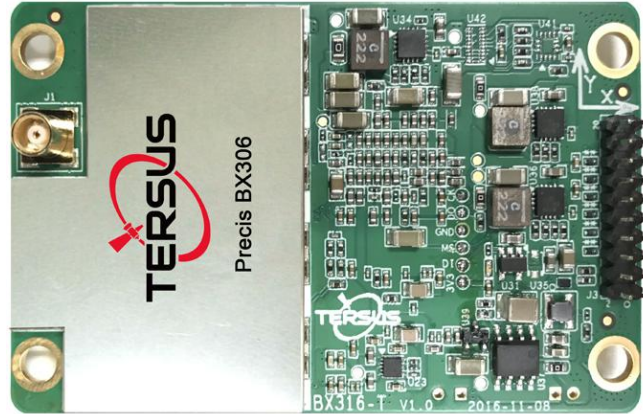

Figure 1 Overview of BX306 Board

Table 2 Features of BX306 Board

Supports three constellations, six frequencies: GPS L1/L2, GLONASS G1/G2, BDS B1/B2	Supports NMEA-0183 and Tersus Binary format
Log & Command compatible with Novatel Protocol	Pin to Pin compatible with Novatel 615
Correction: RTCM 2.x/3.x/CMR/CMR+	Up to 20Hz RTK solution and raw data output <sup>1</sup>
Up to 4GB internal eMMC for data collection.	Compact design

The technical specification of BX306 board is provided in chapter 4.

Note 1: 20Hz solution is related to FW release, contact Tersus support before it's used.

Two LEDs are installed on the BX306 board, whose definition is given in Table 3:



Table 3 LED Definition of BX306 board

LED	Colour	Description
LED1 (left)	ORANGE	Blink 1Hz: if log is output at 1Hz or less. Blink the same rate as the log if log output rate >1Hz.
LED2 (right)	GREEN	ON: RTK fixed. Blink: RTK float solution. OFF: Other position types.



After power on, both LED1 and LED2 are ON for 3 – 5 seconds, then both are OFF for 2 seconds. After that, LED1 will blink at 1Hz.  
The BX306 board is NOT booting up successfully if the LEDs are not acting as the above.

### 1.2.2 OEM BX306Z Board

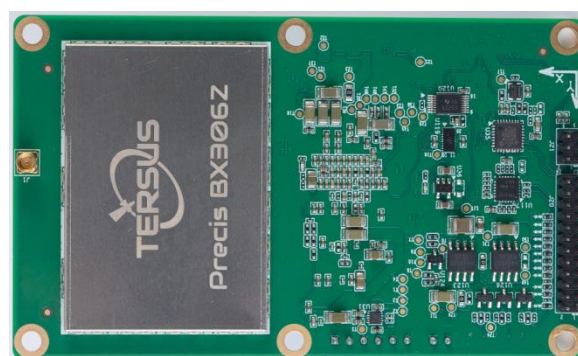

Figure 2 Overview of BX306Z Board

Table 4 Features of BX306Z Board

Supports three constellations, six frequencies GPS L1/L2, GLONASS G1/G2, BDS B1/B2	Supports NMEA-0183 and Tersus Binary format
Log & Command compatible with Novatel Protocol	Pin to Pin compatible with Trimble BD970
Correction: RTCM 2.x/3.x/CMR/CMR+	Up to 20Hz RTK solution and raw data output <sup>1</sup>
Up to 4GB internal eMMC for data collection.	

The technical specification of BX306Z card is provided in chapter 5

Note 1: 20Hz solution is related to FW release, contact Tersus support before it's used.

Three LEDs are on the BX306Z board, the definition is given in Table 5.



Table 5 LED Definition of BX306Z Board

LED	Colour	Description
LED1 (left)	ORANGE	ON: RTK corrections are received. OFF: RTK corrections are not received.
LED2 (middle)	ORANGE	ON: after power on.
LED3 (right)	GREEN	Blink: RTK float. ON: RTK fixed. OFF: other position types

	After power on, all the three LEDs are ON for 3 – 5 seconds, then all are OFF. After 2 seconds, LED2 will be ON.
---	--

	The BX306Z board is NOT booting up successfully if the LEDs are not acting as the above.
--	--

### 1.2.3 OEM BX316D Board

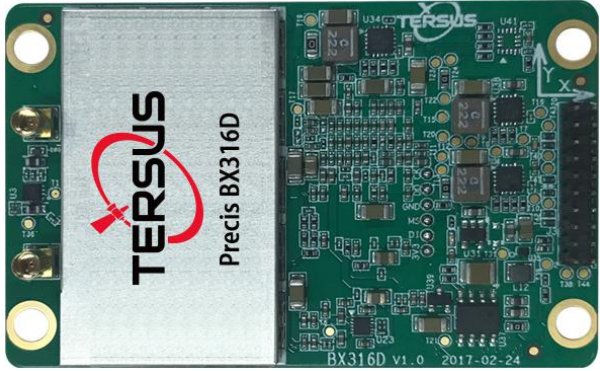

Figure 3 Overview of BX316D Board

Table 6 Features of BX316D Board

Supports three constellations, six frequencies GPS L1/L2, GLONASS G1/G2, BDS B1/B2	Supports NMEA-0183 and Tersus Binary format
Log & Command compatible with Novatel Protocol	Pin to Pin compatible with Novatel 617D
Correction: RTCM 2.x/3.x/CMR/CMR+	Up to 20Hz RTK solution and raw data output <sup>1</sup>
Supporting heading	Compact design
Up to 4GB internal eMMC for data collection.	

The technical specification of BX316D board is provided in chapter 6.

Note 1: 20Hz solution is related to FW release, contact Tersus support before it's used.

Two LEDs are installed on the BX316D board, whose definition is given in Table 7:

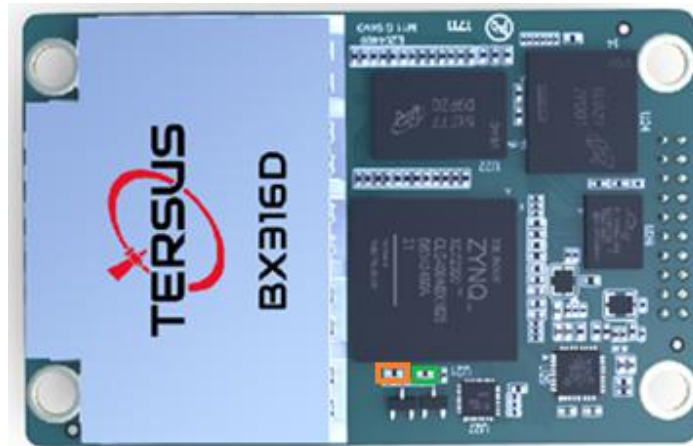



Table 7 LED Definition of BX316D Board

LED	Colour	Description
LED1 (left)	ORANGE	Blink 1Hz: if log is output at 1Hz or less. Blink the same rate as the log if log output rate >1Hz.
LED2 (right)	GREEN	ON: RTK fixed. OFF: RTK not fixed.

	<p>After power on, both LED1 and LED2 are ON for 3 – 5 seconds, then both are OFF for 2 seconds. After that, LED1 will blink at 1Hz.</p> <p>The BX316D board is NOT booting up successfully if the LEDs are not acting as the above.</p>
---	--

#### 1.2.4 BX306 Enclosure



Figure 4 Overview of BX306 Enclosure



Table 8 Features of BX306 Enclosure

Feature	BX306 Enclosure
OEM Card	BX306 board
Serial ports	2 LVTTTL serial port <sup>1</sup>
Antenna interface	Single SMA
USB	USB 2.0
Input power	+5~+12VDC
Power interface	USB type A
GPS+BDS+GLONASS positioning	Yes
PPS	Yes
Event	Yes

The technical specification of BX306 enclosure is provided in chapter 7.

Note 1: The specific 20-pin cable has a COM3 connector, but its function is related to the firmware version, please check with Tersus support.

Two LEDs are given on the BX306 enclosure panel, the definition is in Table 9.



Figure 5 BX306 Enclosure Panel

Table 9 LED Definition of BX306 Enclosure

LED	Colour	Description
LED1	RED	ON: RTK fixed. OFF: RTK not fixed.
LED2	RED	ON: after power on.

	<p>After power on, both LED1 and LED2 are ON for 3 – 5 seconds, then LED1 will be OFF, while LED2 keeps ON.</p> <p>The BX306 enclosure is NOT booting up successfully if the LEDs are not acting as the above.</p>
--	--

## 1.2.5 BX316 Enclosure



Figure 6 Overview of BX316 Enclosure

Table 10 Features of BX316 Enclosure

Feature	BX316 Enclosure
OEM Card	BX316 board
Serial ports	2 LVTTTL serial port <sup>1</sup>
Antenna interface	Double SMA
Input power	+5~+12VDC
Power interface	USB type A
USB	USB 2.0
GPS+GLONASS+BDS in position and heading	Depends on the antenna mode, refer to command ANTENNAMODE in the Log & Command document for detail.
External SD card	Yes
Heading	Yes
PPS	Yes
Event	Yes

The technical specification of BX316 enclosure is provided in chapter 8.

Note 1: The specific 40-pin cable has a COM3 and Ethernet connectors, but their function is related to the firmware version, please check with Tersus support.

Refer to section 2.8 for detail about how to output heading.

Four LEDs are provided on the BX316 enclosure panel, see Table 11 for definition.

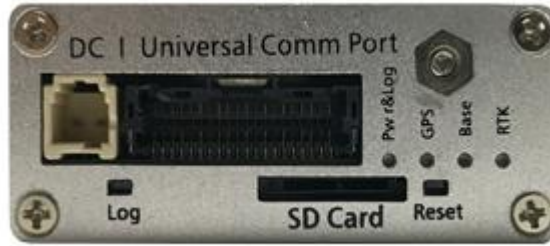

Figure 7 BX316 Enclosure Panel

Table 11 LEDs on BX316 Enclosure Panel

LED	Colour	Description
PWR & Log	GREEN	ON: if there is no data collection to SD or eMMC card. Blink: data saved to SD or eMMC card.
GPS	WHITE	Default: 1Hz blink If data output at higher rate, the blink rate will increase accordingly.
Base	GREEN	OFF: no RTK corrections are received. ON: RTK corrections can be received.
RTK	BLUE	OFF: RTK not fixed. ON: RTK fixed.

	<p>After power on, All the four LEDs are ON for 3 – 5 seconds, then all are OFF for 2 seconds, PWR&amp;Log LED will be ON or blink. GPS LED will blink.</p> <p>The BX316 enclosure is NOT booting up successfully if the LEDs are not acting as the above.</p>
--	--

### 1.2.6 BX316R Enclosure

BX316R enclosure is designed specifically for post processing applications, such as mobile mapping or monitoring system. It has the same hardware as that of BX316, but it can't support RTK positioning or heading.

	<p>BX316R can support RTK positioning and heading after an auth code is input. Contact Tersus sales for more detail about business.</p>
--	---



Figure 8 Overview of BX316R Enclosure

Table 12 Features of BX316R Enclosure

Feature	BX316R Enclosure
OEM Card	BX316R board
Serial ports	2 LVTTL serial port <sup>1</sup>
Antenna interface	Two SMA connectors <sup>2</sup>
Input power	+5~+12VDC
Power interface	USB type A
USB	USB 2.0
GPS+GLONASS+BDS in position	Yes
External SD card	Yes
Heading	Yes
PPS	Yes
Event	Yes
Heading	No

The technical specification of BX316R enclosure is provided in chapter 9.

Note 1: The specific 40-pin cable has a COM3 connector, but its function is related to the firmware version.

Note 2: Only P-ANT interface can work.

BX316R enclosure has the same LEDs on panel as BX316 enclosure, and has the same the booting up mode as BX316 enclosure. Refer to section 1.2.5 for the LEDs definition of BX316R.

### 1.3 BX Receivers System Overview

To make OEM BX series boards work, the following parts are necessary:

- ◇ Interface board, or enclosure and cables
- ◇ Power supply
- ◇ Data communications equipment
- ◇ GNSS antenna with Low Noise Amplifier

The BX series receivers are illustrated in Figure 9

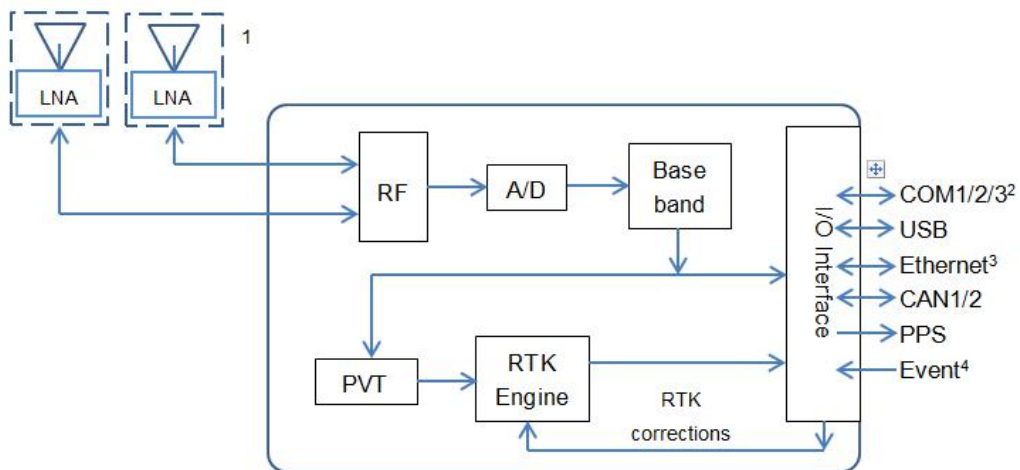

Figure 9 System Overview of BX Boards

Note 1: Only BX316 and BX316D can support the secondary antenna.

2: COM3 is related to FW version, please contact support before it's used.

3: Only BX316 and BX316R can support Ethernet port.

4: Some receivers can support two event inputs, please contact Tersus support before event2 is used.

### 1.3.1 BX Series OEM Boards

BX series OEM boards consist of a Radio Frequency (RF) section and a digital section.

#### Radio Frequency (RF) Section

The receiver obtains filtered, amplified GNSS signals from the antenna. The RF section down converts the incoming RF signals to Intermediate Frequency (IF) signals which are processed by the digital section. The RF section also supplies power to the active antenna LNA through the coaxial cable. The RF section has been designed to reject common sources of interference.

## Digital Section

The heart of the digital section is the base band, which is realized with a FPGA chip. The digital section digitizes and processes the base band signals to obtain a PVT (Position, Velocity and Time) solution. If RTK corrections from the base are received, the receiver will output cm-level position. The digital section also processes the system I/O, shown in Figure 9.

### 1.3.2 BX Enclosures

An enclosure is necessary to protect the OEM BX series boards from environmental extremes and high levels RF interference, and it brings convenience for the customers to use the receivers.

### 1.3.3 Antenna

The antenna converts electromagnetic signals transmitted by GNSS satellites into electrical signals that can be used by the receiver.

An active GNSS antenna is required for optimal receiver performance. Tersus is providing active GNSS antennas with precise phase centers and robust enclosures (refer to <https://www.tersus-gnss.com/product/accessories> for more about antennas.

### 1.3.4 Power Supply

A power supply capable of delivering the minimum receiver operating voltage and power is required. See section 2.4 for detail.

### 1.3.5 Communication Equipment

A computer, a tablet or other data communications device are necessary to communicate with the receiver, and to receive and store the data that the receiver outputs.

### 1.3.6 External SD/Internal eMMC Card

!	The external SD card must meet: Size ≤ 16GB. File system: FAT32.
---	--

!	The SD card must be installed into the external datalogger before it's used, refer to section 10.4 for detail. All the BX receivers are supporting up to 4GB internal eMMC card by FW0020 or later release.
---	--

The data can be saved on an external SD or an internal eMMC card manually or automatically, which is determined by command LOGFILE.

### 1.3.7 Enable Heading

!	Only OEM BX316D board and BX316 enclosure can support heading output.
---	---

The defaults configure of BX316D and BX316 is in single antenna mode, in which heading output is not supported. Heading output is supported only when they're in dual antenna mode. Command ANTENNA MODE must be input to select the antenna mode, see chapter 2.8 Heading Output for detail.

!	When in single antenna mode, the connector for the secondary antenna connector can be left float.
---	---

## 2. Installation

---

This chapter describes how to set up a BX receiver to make it work. In order to perform RTK positioning, BX receiver need the GNSS satellites signals input from the antenna and RTK corrections input from a serial port.

!	The installation is take BX306 enclosure as the example, BX series OEM boards can be integrated to the customer's system in various packages, all actions can refer to the installation guide in this chapter.
---	--

### 2.1 Shipping Box

Generally, the BX series receivers are shipped in a plastic box. The following receivers/accessories can be in the standard KIT package.



Figure 10 Parts in the Kit Package



## 2.2 USB Adapter

The BX enclosure receivers will communicate with other devices via a serial port, which could be connected to a USB adapter, see Figure 11.



Figure 11 USB Adapter

Please download the proper USB adapter driver according to your operating system from <http://www.ftdichip.com/Drivers/VCP.htm>

After the USB adapter is installed on your computer successfully, you can find it in device manager, see Figure 12. BX306 is connected to the USB adapter and any serial software tool can communicate with the BX306.

Tersus GNSS Center, a graphic serial tool, is recommended to communicate with the receiver. It can be freely downloaded from <https://www.tersus-gnss.com/software> . Figure 16 shows the main windows of Tersus GNSS Center, refer to section 2.6 for more.

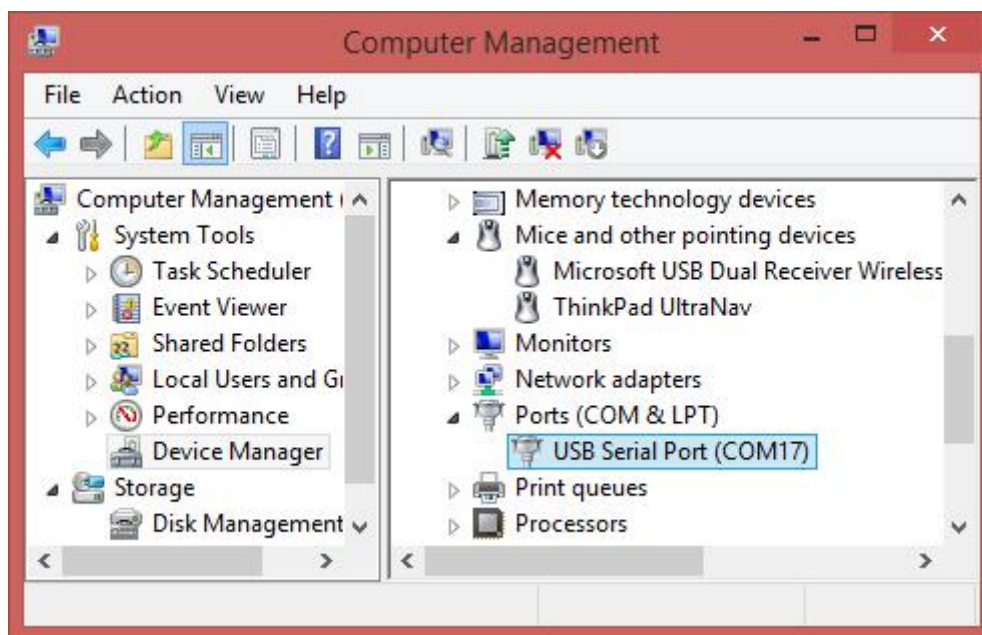

Figure 12 Device Manager

## 2.3 Selecting a GNSS Antenna

The antennas provided by Tersus can be found in <https://www.tersus-gnss.com/product/accessories>. It's highly recommended the antennas from Tersus are used to work with BX series receivers.



Figure 13 Antennas from Tersus

Generally, AX3702 is widely used in survey application and is recommended for all other applications.

AX3703 is recommended for UAV application.

AX3704 is for Tersus TX series receivers.

AX3705 is a solution for UAV.



Contact Tersus support if problems happen when an antenna from other vendors are used.

When installing the antenna:

- Choose an antenna location with a good view of the sky so that there is no obstruction from horizon to horizon.
- Mount the antenna on a secure, stable structure capable of safe operation in the specific environment.

## 2.4 Power Supply Requirement



Power to the BX series OEM boards must be applied for >150ms before any of the external interfaces are powered on by the integrator's card.  
Hold the RESETIN pin low during power up and for >150ms after power is applied.



If the voltage supplied is below the minimum specification, the receiver suspends operation. If the voltage supplied is above the maximum specification, the receiver may be permanently damaged, voiding the warranty.



The LEDs on the OEM boards/enclosures can tell whether the receiver is booting up successfully or not, see the detailed info from section 1.2.1 to 1.2.6.

The input power requirement for the BX series receivers are given in Table 13

Table 13 Input Power Requirements

BX series receivers	Input Power Requirement
OEM BX306 board	+3.3 VDC +5%/-3% with less than 100 mV ripple
OEM BX306Z board	+3.3 VDC +5%/-3% with less than 100 mV ripple
OEM BX316D board	+3.3 VDC +5%/-3% with less than 100 mV ripple
BX306 enclosure	+5~+12VDC
BX316 enclosure	+5~+12VDC
BX316R enclosure	+5~+12VDC



None of the BX receivers are supporting reversed polarity protection

## 2.5 OEM Boards Installation Overview

When the appropriate equipment is selected, complete the following steps to set up and begin using the BX series receivers.

- a) Install the BX board in an enclosure or on a mother board.
- b) Mount the GNSS antenna to a secure, stable structure.
- c) Connect the GNSS antenna to the receiver with a RF cable.
- d) Apply power to the receiver, as described in section 2.4.
- e) Connect the receiver to a computer or other data communications equipment.



When OEM BXs series boards are handled, follow the guides below to avoid damage from ESD.

- Always wear a properly grounded anti-static wrist strap when handling BX series boards.
- Always hold the card by the corners or the RF shield: avoid direct contact with any of the components.
- Never let the board come in contact with clothing. The ground strap cannot dissipate static charges from fabrics.
- Failure to follow accepted ESD handling practices could cause damage to the board permanently.
- The warranty may be void if equipment is damaged by ESD.

## 2.6 Tersus GNSS Center Software

BX receivers have serial ports, so lots of serial tools can be used to communicate with the receivers. Tersus GNSS Center is a windows-platform-based serial tool, which is recommended to communicate with the BX receivers. Tersus GNSS Center can be downloaded in <https://www.tersus-gnss.com/software>

Run Tersus GNSS Center, the following config page is shown, input the port and band rate (default is 115200).

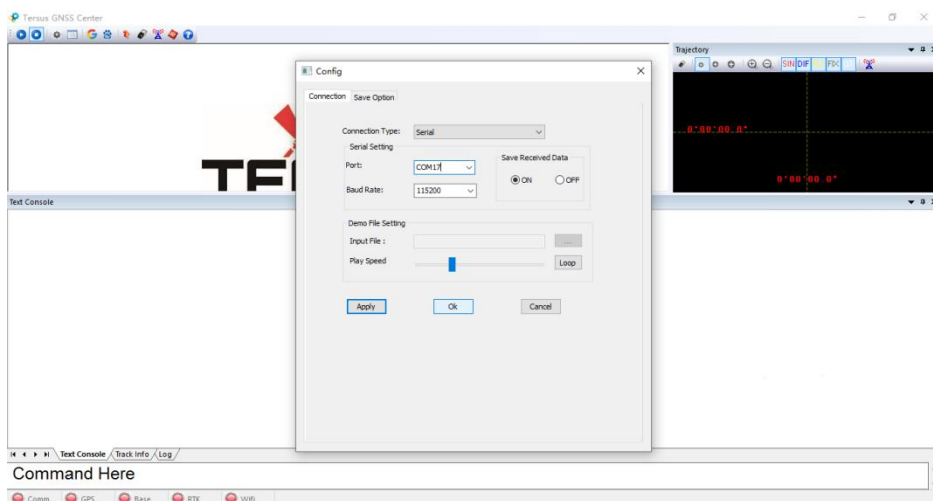

Figure 14 Config Page of Tersus GNSS Center

Table 14 gives definition for the four LEDs at the bottom of Tersus GNSS Center.

Table 14 Definition of the LEDs on Tersus GNSS Center

LEDs	Description
COMM	GREEN: the communication with the receiver is established. RED: the communication with the receiver is not established.
GPS	GREEN: valid GPGGA is received. RED: No valid GPGGA is received.
Base	GREEN: valid corrections are received. RED: No valid corrections are received.
RTK	SOLID GREEN: RTK solution is got. BLINK GREEN: float solution is got. RED: other solutions are got.
Wifi	Reserved.



Figure 15 BX306 Enclosure Connected to a Laptop

Figure 15 shows a BX306 enclosure is connected to a laptop with a 20-pin cable and an USB adapter.

Commands can be input in the text console window, an OK response is output after a command is input, or the command is not input successfully.

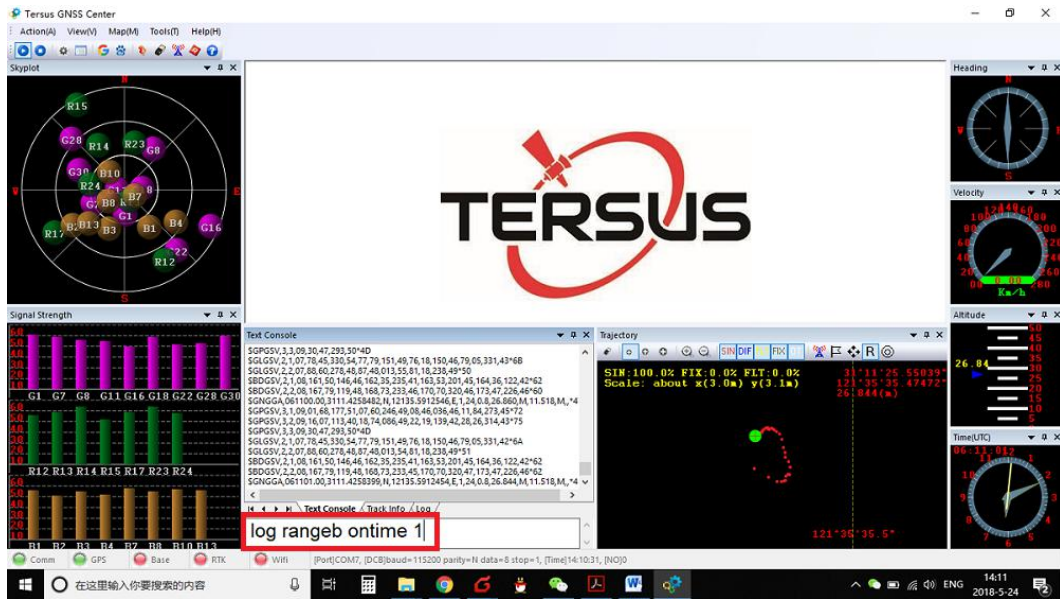

Figure 16 Main Windows of Tersus GNSS Center

!	<p>To activate the skyplot, signal strength, trajectory and other windows, the antenna signals must be received and the following three loggings must be input to the receiver:</p> <pre>LOG GPGGA ONTIME 1 // output position and time LOG GPGSV ONTIME 1 // output SVs in view, elevation and SNR (Signal Noise Ratio) LOG RNAGEB ONTIME 1 // output PSR (Pseudorange) and ADR (Accumulated Doppler Range.)</pre>
---	---

### 2.6.1 Auto Base Station List Function

If a base is setup with command POSAVE, according to its original definition, even if the receiver is installed at the same point. After a power cycle, the fixed position may be different, see more about command POSAVE in the Log & Command document. For the users who want the base to keep the same fixed position after a power cycle, auto base station list function is introduced.

The procedure is introduced below:

- 1) Communicate the receiver with Tersus GNSS Center, refer to section 2.6.
- 2) Go to Menu Tool -> Base Network for Posave, the following page will be displayed.

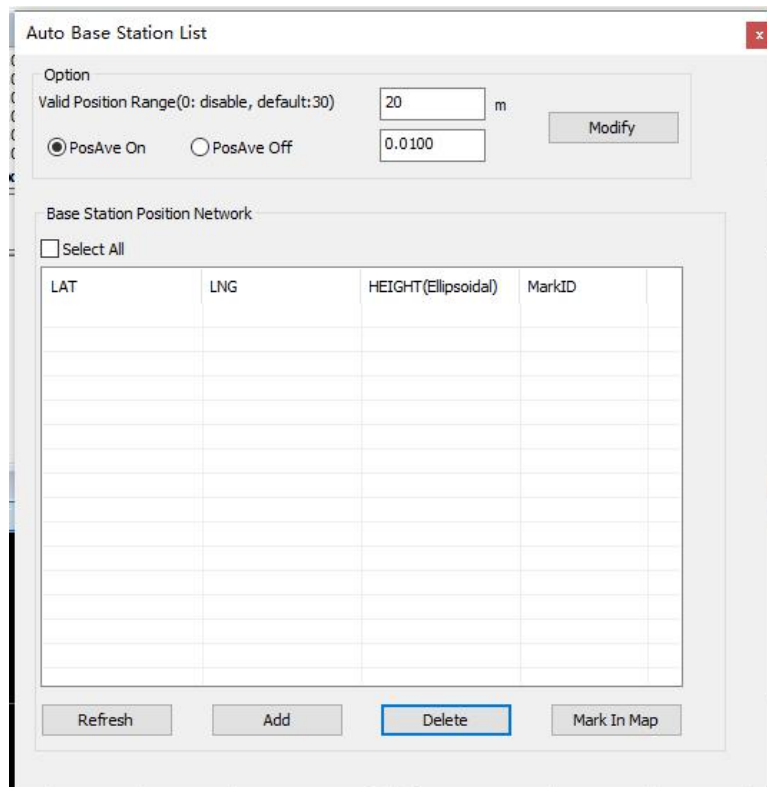

- 3) Fill the valid position range, PosAve On and fill the time (unit is hour), press the Modify button. It's recommended that valid position range is >20m.
- 4) After the time (in the example, 0.01 hour, that is, 36 seconds), the base will be fixed with the 36 seconds averaging position.
- 5) Press Refresh button, the fixed position will be displayed on the window.

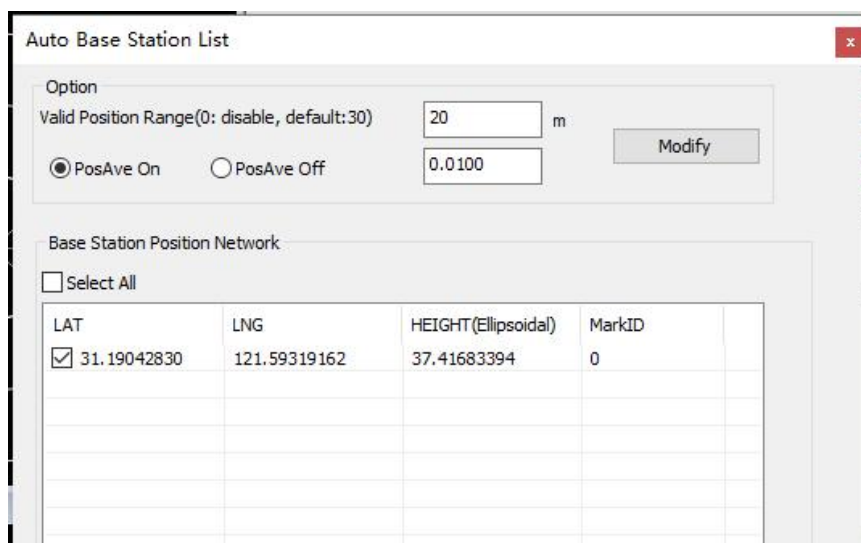

- 6) Then after a power cycle, if the base is not moved 20m away from the last position, it will fixed with the same position, in the example, latitude will keep 31.19042830,

longitude will keep 121.59319162 and ellipsoid height will keep 37.4168.

## 2.7 Transmitting and Receiving Corrections

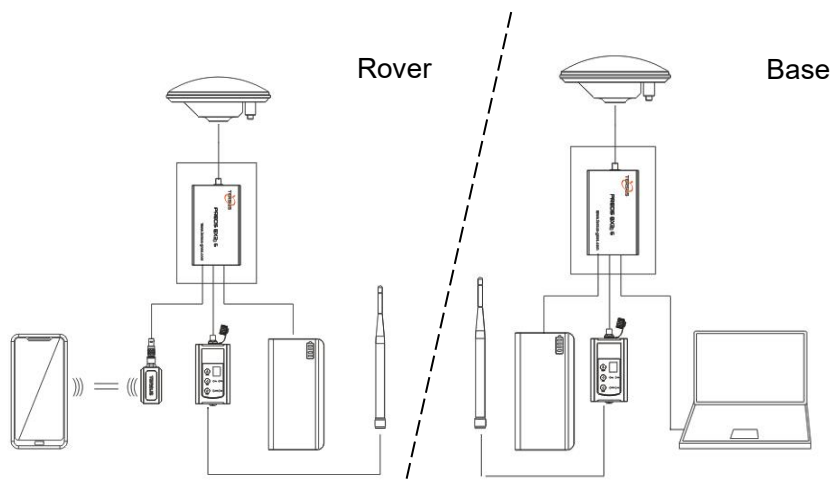

Figure 17 Base/Rover Configure

Example of RTK configuration (base mode):

```
COM COM2 115200 //set the baud rate, optional
INTERFACEMODE COM2 AUTO AUTO ON //set the interfacemode, optional
FIX POSITION LAT LON HGT //input the position of the base

LOG COM2 RTCM1074 ONTIME 1 //output GPS RTK raw measurements
LOG COM2 RTCM1084 ONTIME 1 // output GLONASS raw measurements
LOG COM2 RTCM1124 ONTIME 1 // output BDS RTK raw measurements
LOG COM2 RTCM1005 ONTIME 10 // output the base's position
SAVECONFIG //save the configure above
```

Example of RTK configuration (rover mode):

```
COM COM2 115200 //set the baud rate, optional
INTERFACEMODE COM2 AUTO AUTO ON //set the interfacemode, optional
LOG GPGGA ONTIME 1 //output GPGGA to check position type
SAVECONFIG //save the configure above
```

!

The base's antenna must be static and its position must be input, several ways can be used to input the base's position:



	<ul style="list-style-type: none"> <li>● If the base's position is known, input it directly with command FIX.</li> <li>● If the base's position is unknown, and the accuracy of the base can be meter-level, then it's recommended to use command POSAVE to setup the base, see the Log &amp; Command document for more about this command. Please note the base's position will be different after a power cycle even if the antenna is installed at the same point if POSAVE command is input.</li> <li>● If you require a cm level accuracy of base and rover, then: <ul style="list-style-type: none"> <li>A. Configure the base receiver as a rover, receive RTK corrections from a CORS nearby, this receiver can get cm-level accuracy position.</li> <li>B. Collect raw measurements for half an hour, process it with post processing software or send the data to an online processing web, e.g. OPUS, to get an accurate position.</li> </ul> </li> </ul>
--	--

## 2.8 Heading Output

!	Only BX316D board and BX316 enclosure can support heading output.
---	---

The defaults configure of BX316D and BX316 is in single antenna mode; heading output is supported only when they're in dual antenna mode. To output heading, follow the steps below:

- 1) Connect two GNSS antennas to the primary and secondary connectors, respectively.
- 2) Input one of the two commands below to select dual antenna mode.

ANTENNAMODE DUALGPSBDS // Primary antenna tracks GPS L1/L2, BDS B1/B2;  
secondary antenna tracks GPS L1, BDS B2

ANTENNAMODE DUALGPSGLO // Primary antenna tracks GPS L1/L2, GLO G1/G2;  
secondary antenna tracks GPS L1, GLO G2

- 3) LOG HEADING ONTIME 1 // heading output
- 4) SAVECONFIG // save the configure above.
- 5) Power cycle the receiver.

	The command ANTENNAMODE will not work before a power cycle is input.
---	--

!	In single antenna mode, the raw measurements in RANGE log are from the primary antenna only.
---	--

	In dual antenna mode, the raw measurements from both the primary antenna and the secondary one are included in RANGE log.
--	---

!	It's recommended that the distance between two antennas is >1m. It's strongly recommended the distance is 0.5m at least.
---	---

## 3 FW Update and Auth Code

---

### 3.1 Firmware Updates

If a new firmware update is released, it will be available on the Tersus web site, or you can get the updates from Tersus support.

The FW version of a Tersus receiver can be updated in field. Connect the COM2 port of the receiver with Tersus GNSS Center, and input 'LOG VERSION', the following info will be output:

```
VERSION COM1 0 0.0 UNKNOWN -1 0.000 00000000 0 20161214
< 1
< BX306 G2SB2G2 008001181300000026 0020 20161123 3.0 Mar 16 2018
00:39:52
```

0020 is the FW version. See 'VERSION' in Tersus GNSS Log & Command Reference document for more detail.

### 3.2 Upgrading FW Using Tersus GNSS Center

Please follow the steps below to upgrade the FW.

- 1) Power on the receiver.
- 2) Run Tersus GNSS Center software and communicate with the receiver, see section 2.6 for detail. Make sure the receiver has finished initialization, which can be confirmed by input 'LOG VERSION' in the console window and the receiver will output feedback.



- 3) Press Stop button to terminal the communication between the computer and the receiver.



- 4) Select Tools ->UpdateFirmware

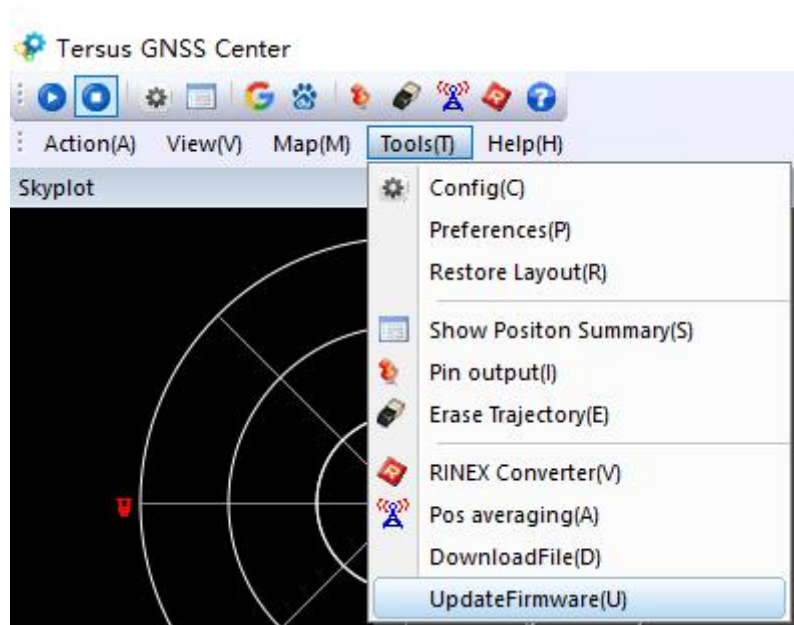

- 5) Select the upgrade file, when a file is selected, the file will be shown in the Update File bar. Select the port and baud rate, press Next

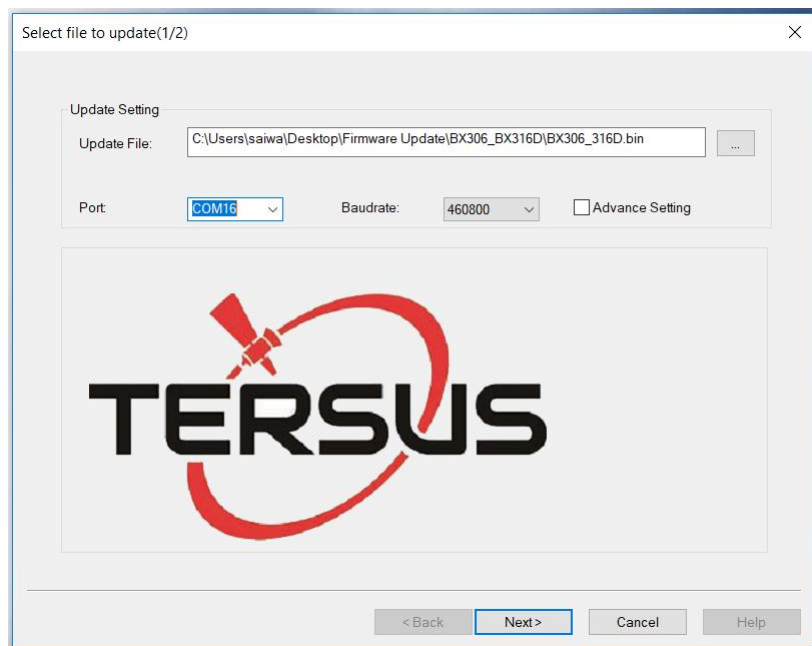

- 6) The following figure shows the FW is upgrading, two progresses are included in the FW update.

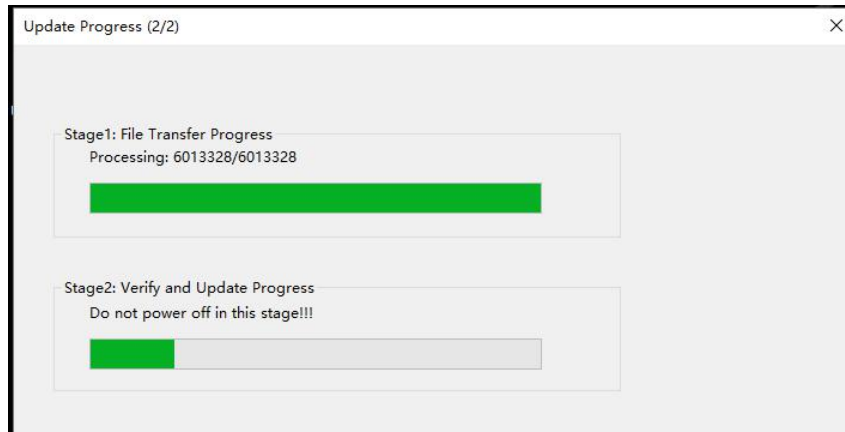

 Do not power off the receiver during the verify and update process.

7) After the FW is upgraded successfully, The following show

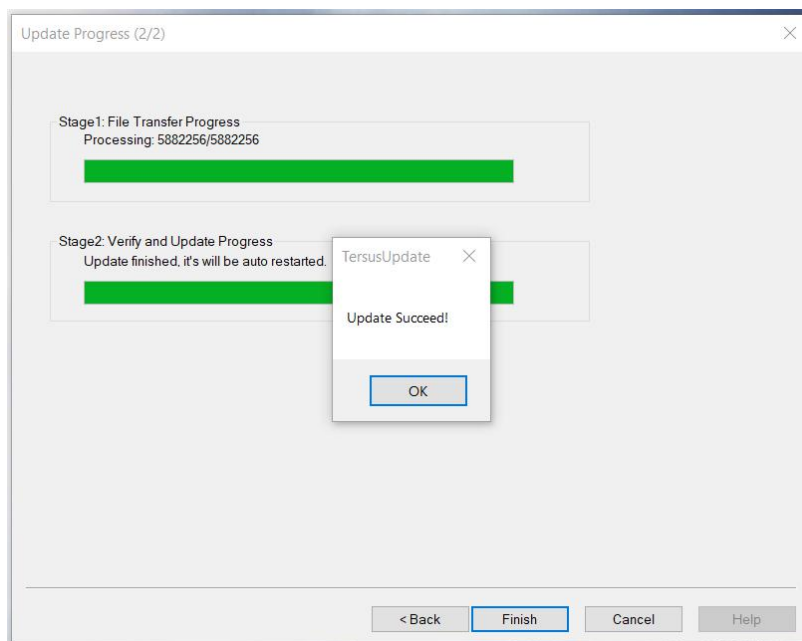

- 8) Press OK and Finish buttons to close the FW upgrade windows, the receiver will reset automatically.
- 9) After the board is booted, you can confirm the FW version by connecting to the receiver and input 'LOG VERSION' and check the FW version.

**There is Advance Setting option in the FW update page, If a receiver**

- can't boot up successfully, or

- can't work well after boot up, or
- can't finish FW update successfully according to the above steps, you can select Advance Setting option to start FW update again.

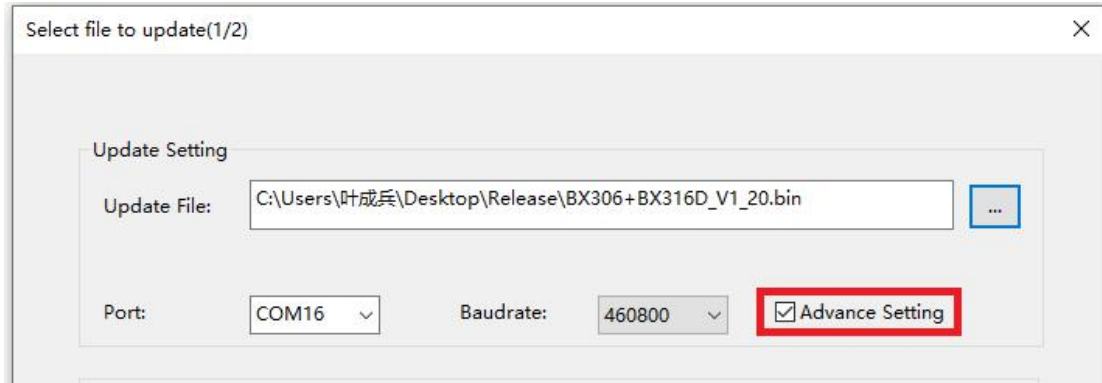

If it's selected, the following page will be displayed, select 'Manual Hardware Reset' and press OK.

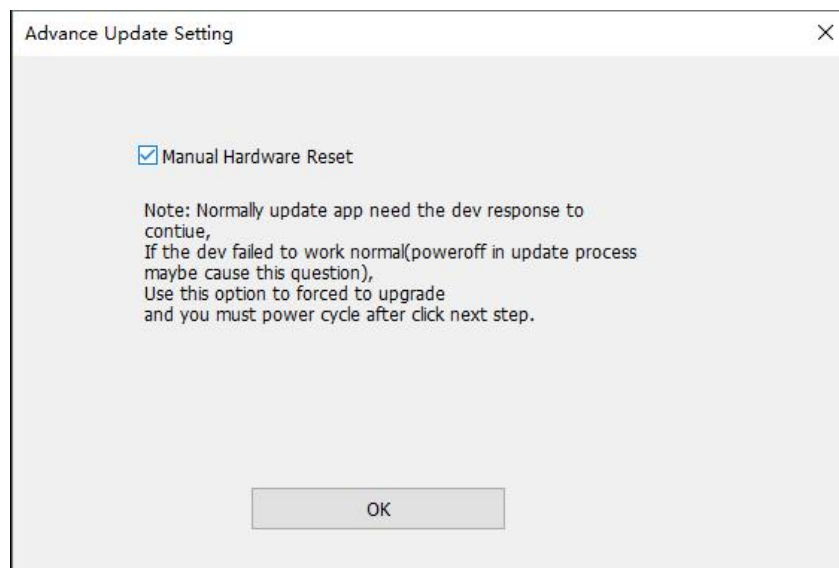

Press Next in the former page and power off the receiver, wait for 5 seconds and power on it again.

After FW update is finished, power off the receiver, wait for 5 seconds and power on it again.



This option is for sophisticated users. If you're not sure whether it should be selected, contact Tersus support before select this option.

### 3.3 Auth Code

An auth code is used to determine the features and valid time for a receiver. If the auth code is expired, the receiver will not work. And a license requirement is output from all the ports.

Before you contact Tersus for new auth code, input:

```
LOG VERSION  
LOG AUTHLIST
```

to the receiver, and send all the output info to Tersus support. If the auth code application is approved, you will get a txt file, in which command AUTHCODE and the code will be given, just copy all of them (Ctrl-A & Ctrl-C) and input them to the receiver.

## APPENDIX A

### 4 BX306 Board Technical Specifications

Table 15 BX306 Board Performance

<b>GNSS Performance</b>			
Position Accuracy	Single positioning	1.5m RMS (Horizontal)	
		3.0m RMS (Vertical)	
	RTK Positioning	10mm+1ppm (Horizontal)	
		15mm+1ppm (Vertical)	
Time to First Fix	Cold Start: <50s Warm Start: <30s		
Reacquisition	0.5 s L1 (typical) 1.0 s L2 (typical)		
Data Rate	Measurements	20Hz	
	Position	5Hz	
Time Accuracy	20ns RMS		
Velocity Accuracy	0.03m/s RMS		
Measurement Precision	GPS	L1 PSR	6 cm
		L1 ADR	1.0mm
		L2 PSR	8 cm
		L2 ADR	1.2mm
	BDS	L1 PSR	6 cm
		L1 ADR	1.0mm
		L2 PSR	8 cm
		L2 ADR	1.0mm
	GLONASS	L1 PSR	8 cm
		L1 ADR	1.0mm
		L2 PSR	8 cm
		L2 ADR	1.0mm
<b>Physical Description</b>			
Size	71 * 46 * 8.8 mm <sup>3</sup>		
Weight	26g		
<b>Mechanical Drawing</b>			



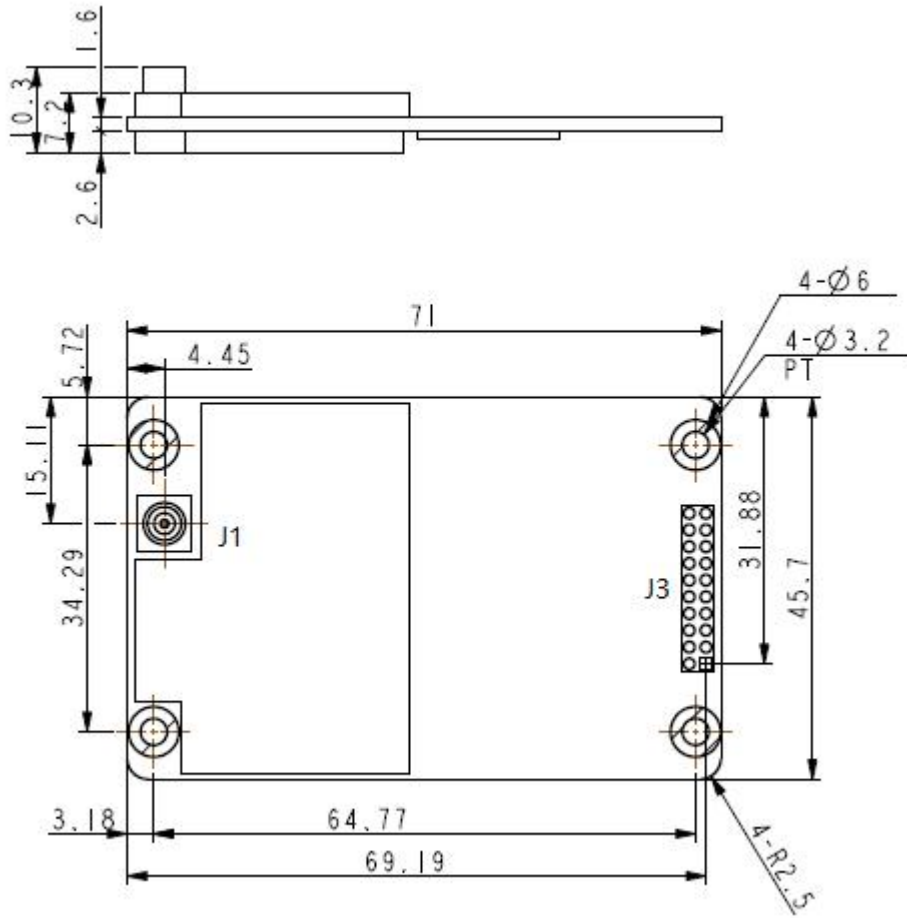

**HEAT SINK POSITION<sup>1</sup>**

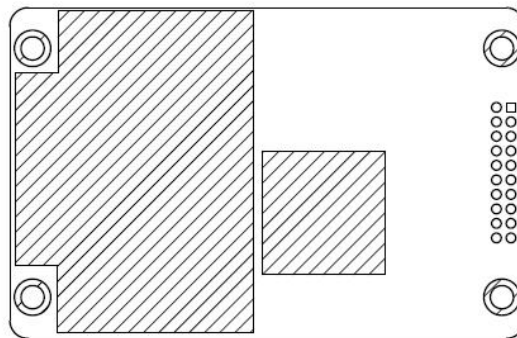

**ENVIRONMENTAL**

Operating Temperature	-40C to +85C
Storage Temperature	-55C to +95C
Humidity	MIL-STD-810G, Method 507.5 Procedure II (95%)
Random Vibration	MIL-STD 810G Method 514.6, Category 24 (7.7 g RMS)
Sinusoidal Vibration	IEC 60068-2-6 (5 g)
Bump	ISO 9022-31-06 (25 g)

Shock	Operating: MIL-STD-810G, Method 516.6, Procedure I (40 g) Non-operating: MIL-STD-810G, Method 516.6, Procedure V (75 g)
<b>Power Requirement</b>	
Input Voltage	+3.3 +5%/-3% VDC
Allowable Voltage Ripple	100 mV p-p maximum
Power Consumption	2.8W (typical)

Note 1: when BX306 board is assembled in a box, a head sink must be installed between the hatch area and the metal box, or the thermal performance of the card will be decreased.

#### 4.1 Connectors on BX306 board

There are two connectors on the BX306 board, J1 and J3, see the mechanical drawing in the above table.

J1: MCX jack receptacle, straight (Johnson P/N 133-3711-202 or SAMTEC P/N MCX-J-P-HST-SMI or equivalent)

J3: 2x10 header, 2 mm pitch (SAMTEC P/N TMM-110-03-G-D)

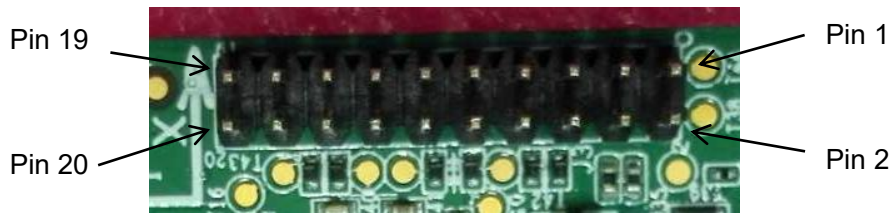

Table 16 Interface Signals Definition

Pin	Signal	TYPE	Description	Comments
1	LNA_PWR	PWR	Antenna power input	Power to antenna, 3.3~12VDC.
2	3V3	PWR	Power to the board	3.3 V +5%/-3%
3	USB_D-	IO	USB data (-)	One-half of a differential pair (pins 3 and 4). Match lengths and route as a 90 Ω differential pair if USB is required
4	USB_D+	IO	USB data (+)	

5	/RESETIN	I	Reset input t	Active low reset
6	USERVARF	IO	Variable frequency output	
7	EVENT2	IO	Event 2 Input	
8	N.C			
9	EVENT1	IO	Event1 input	Has a 10K pull-up resistor on card.
10	GND	PWR	Signal and power ground	
11	TXD1	O	COM1 transmit data	LVTTTL level, the max band rate is 921600 bps.
12	RXD1	I	COM1 receive data	
13	GND	PWR	Signal and power ground	
14	TXD2	O	COM2 transmit data	LVTTTL level, the max band rate is 921600 bps.
15	RXD2	I	COM2 receive data	
16	GND	PWR	Signal and power ground	
17	PV	O	Position valid indicator	High: when RTK solution is got. Low: other position types.
18	GND	PWR	Signal and power ground	
19	PPS	O	Pulse per second output,	This pin has an internal 50 ohm line driver. Route as a 50 $\Omega$ single-ended trace
20	N.C			

## 4.2 Reference Schematic of the Interface Board

If an interface board is designed to work with BX306 card, the following are the reference schematics for the power, serial port, USB port, CAN port and Ethernet port. Please contact Tersus support if you need more about the interface board.

## VDD 3.3V

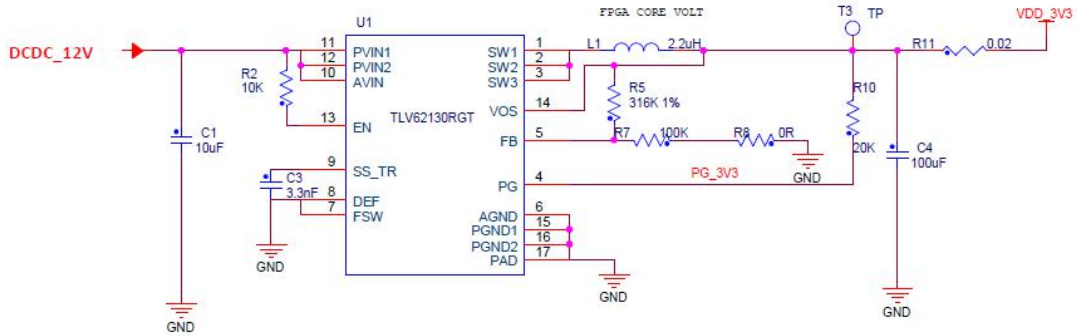

Figure 18 3.3V Reference Schematic

## VDD\_5V

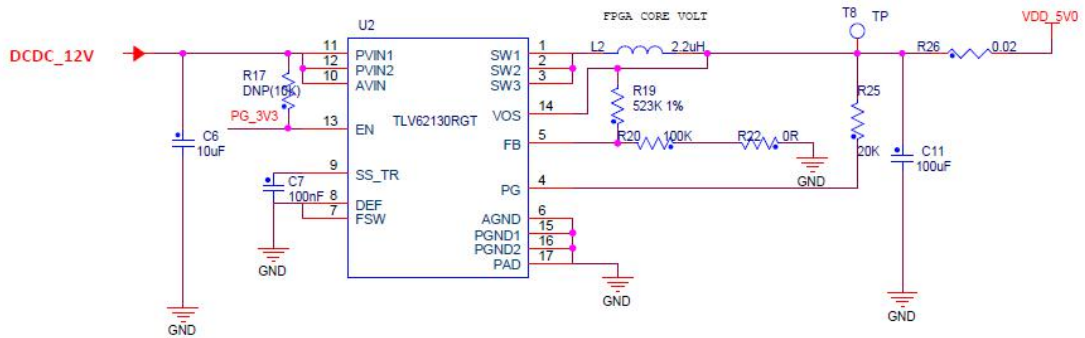

Figure 19 5V Reference Schematic

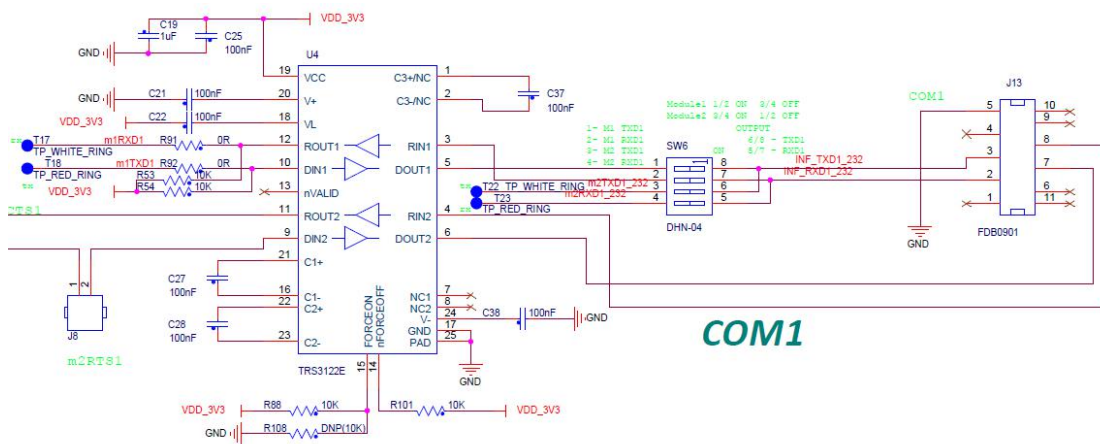

Figure 20 Reference Schematic for a Serial Port

## USB

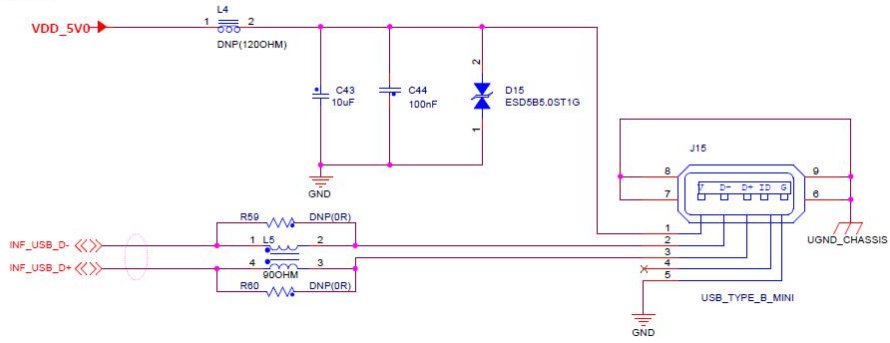

Figure 21 Reference Schematic for USB

## Ethernet

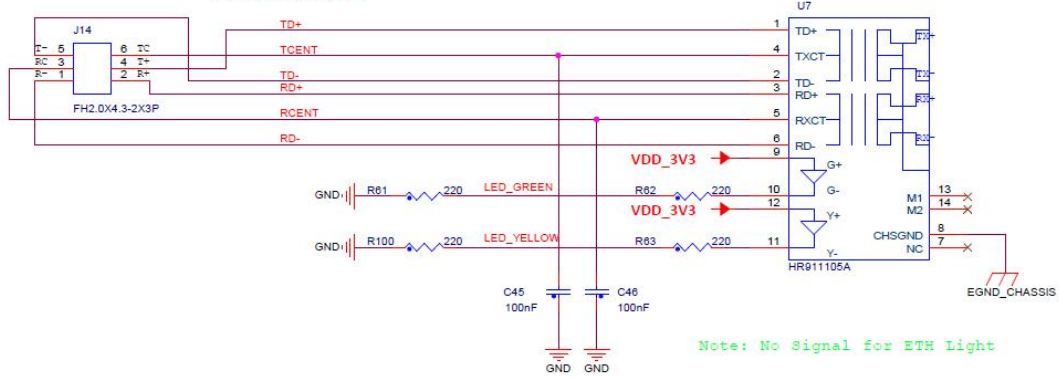

Figure 22 Reference Schematic for Ethernet

## APPENDIX B

### 5. BX306Z Board Technical Specifications

Table 17 BX306Z Board Performance

GNSS Performance			
Position Accuracy	Single positioning	1.5m RMS (Horizontal)	
		3.0m RMS (Vertical)	
	RTK Positioning	10mm+1ppm (Horizontal)	
		15mm+1ppm (Vertical)	
Time to First Fix	Cold Start: <50s Warm Start: <30s		
Reacquisition	0.5 s L1 (typical) 1.0 s L2 (typical)		
Data Rate	Measurements	20Hz	
	Position	5Hz	
Time Accuracy	20ns RMS		
Velocity Accuracy	0.03m/s RMS		
Measurement Precision	GPS	L1 PSR	6 cm
		L1 ADR	1.0mm
		L2 PSR	8 cm
		L2 ADR	1.2mm
	BDS	L1 PSR	6 cm
		L1 ADR	1.0mm
		L2 PSR	8 cm
		L2 ADR	1.0mm
	GLONASS	L1 PSR	8 cm
		L1 ADR	1.0mm
		L2 PSR	8 cm
		L2 ADR	1.0mm
Physical Description			
Size	100 * 60 * 11.6 mm <sup>3</sup>		
Weight	46g		
Mechanical Drawing			

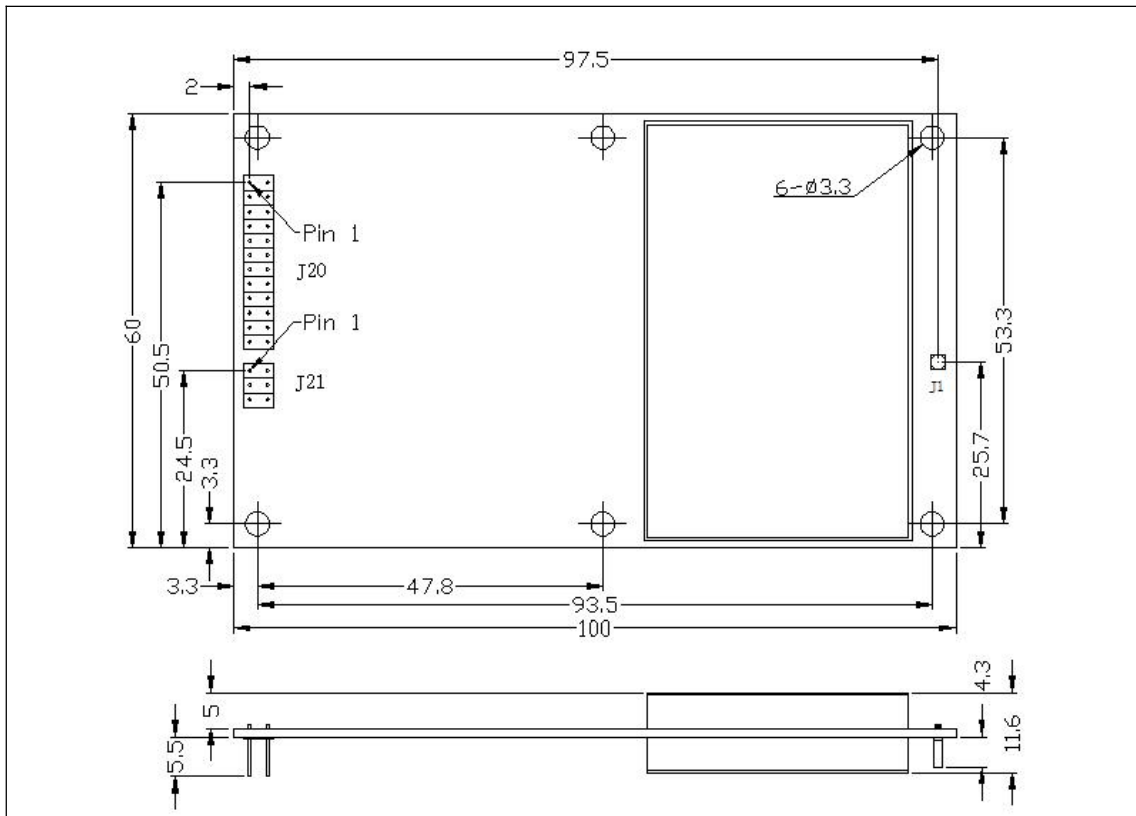

**HEAT SINK POSITION<sup>1</sup>**

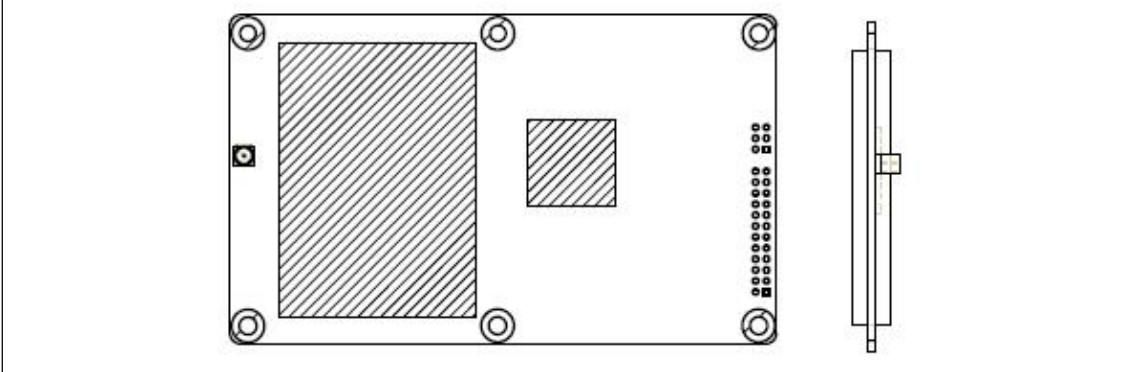

**ENVIRONMENTAL**

Operating Temperature	-40C to +85C
Storage Temperature	-55C to +95C
Humidity	MIL-STD-810G, Method 507.5 Procedure II (95%)
Random Vibration	MIL-STD 810G Method 514.6, Category 24 (7.7 g RMS)
Sinusoidal Vibration	IEC 60068-2-6 (5 g)
Bump	ISO 9022-31-06 (25 g)
Shock	Operating: MIL-STD-810G, Method 516.6, Procedure I (40 g) Non-operating: MIL-STD-810G, Method 516.6, Procedure V

	(75 g)
Power Requirement	
Input Voltage	+3.3 +5%/-3% VDC
Allowable Voltage Ripple	100 mV p-p maximum
Power Consumption	2.9W (typical)

Note 1: when BX306Z card is assembled in a box, a head sink must be installed between the hatch area and the metal box, or the thermal performance of the card will be decreased.

### 5.1 Connectors on BX306Z Board

There are three connectors on the BX306Z card, J1, J20 and J21, see the mechanical drawing in the above table.

1. J20: 2x12 header, 2 mm pitch (SAMTEC P/N TMM-112-03-G-D)
2. J21: 2x3 header, 2 mm pitch (SAMTEC P/N TMM-103-03-G-D)
3. J1: MMCX jack receptacle, straight



Table 18 Interface Signals Definition

Pin	Signal	TYPE	Description	Comments
1	GND	PWR		
2	RTK LED	O	RTK LED. Flashes when an RTK correction is present.	To drive an LED, a series resistor with a 300Ohms is required.
3	POWER_OFF	I	Powers the unit on and off.	Drive high with a 3.3V to turn off, leave floating or ground to keep the unit on.



4	PPS	O	Pulse per second output	This is 3.3V TTL level, 4mA max drive capability.
5	VCC	PWR	Power to the card	3.3V +5%/-3%
6	VCC	PWR	Power to the card	3.3V +5%/-3%
7	Event2 <sup>1</sup> / CAN1_RX / COM3_RX <sup>1</sup>	I	Event2 – Event input CAN1_RX – CAN Receive line COM3_RX – COM3 Receive line	Event2 must be 3.3V TTL level.  Connect COM3_RX to a transceiver if RS-232 level is required.
8	Event1	I	Event input	must be 3.3 V TTL level
9	Power LED	O	POWER Indicator, High when unit is on.	When used to drive an LED, a series resistor with a typical value of 300Ohm is required.
10	Satellite LED	O	Satellite LED. Rapid flash: <5 satellites. Slow flash: >5 satellites.	To drive an LED, a series resistor with 300Ohm is required.
11	COM2_CTS	I	COM2 Clear to Send – TTL Level	Connect COM2_CTS to a transceiver if RS-232 level is required.
12	RESET_IN	I	RESET_IN – ground to reset	Drive low to reset the unit.
13	COM2_RTS	O	COM2 Request to Send – TTL Level	Connect COM2_RTS to a transceiver if RS-232 level is required.
14	COM2_RX	I	COM2 Receive line	Connect COM2_RX to a transceiver if RS-232 level is required.
15	No Connect		Reserved	
16	COM2_TX	O	COM2 transmit line	Connect COM2_TX to a transceiver if RS-232 level is required.
17	No Connect		Reserved	
18	COM1_RX	I	COM1 Receive line	RS-232 Level
19	CAN1_TX / COM3_TX <sup>1</sup>	O	CAN1_TX – CAN Transmit line COM3_Transmit Data – TTL Level	Connect CAN1_TX to TX line of a CAN driver. Connect COM3_TX to a transceiver if RS-232 level is required
20	COM1_TX	O	COM1 Transmit Data	RS-232 Level

21	USB-	I/O	USB D (-) Bi-directional USB interface data (-)	Device Mode only.
22	USB+	I/O	USB D (+) Bi-directional USB interface data (+)	Device Mode only.
23	GND	PWR		
24	GND	PWR		

Pin	Signal	TYPE	Description	Comments
1	ETH_RD <sup>-1</sup>	Differential pair.	Ethernet Receive line minus.	Connect to Magnetics RD-.
2	ETH_RD <sup>+1</sup>	Differential pair.	Ethernet Receive line plus.	Connect to Magnetics RD+.
3	CENT_RD <sup>1</sup>		RD Magnetic center tap.	Connect to Magnetics RD Centre Tap.
4	ETH_TD <sup>+1</sup>	Differential pair.	Ethernet Transmit line plus.	Connect to Magnetics TD+.
5	ETH_TD <sup>-1</sup>	Differential pair.	Ethernet Transmit line minus.	Connect to Magnetics TD-.
6	CENT_TD <sup>1</sup>		TD Magnetic center tap.	Connect to Magnetics TD Center Tap.

Note 1: all the ports are related to FW release, contact Tersus support before use them.

Refer to section 4.2 if interface board is designed.

## APPENDIX C

### 6. BX316D Board Technical Specifications

Table 19 BX306D Board Performance

GNSS Performance			
Position Accuracy	Single positioning	1.5m RMS (Horizontal)	
		3.0m RMS (Vertical)	
	RTK Positioning	10mm+1ppm (Horizontal)	
		15mm+1ppm (Vertical)	
Heading Accuracy	0.2 degree (Baseline is 1m)		
Time to First Fix	Cold Start: <50s Warm Start: <30s		
Reacquisition	0.5 s L1 (typical) 1.0 s L2 (typical)		
Data Rate	Measurements	20Hz	
	Position	5Hz	
Time Accuracy	20ns RMS		
Velocity Accuracy	0.03m/s RMS		
Measurement Precision	GPS	L1 PSR	6 cm
		L1 ADR	1.0mm
		L2 PSR	8 cm
		L2 ADR	1.2mm
	BDS	L1 PSR	6 cm
		L1 ADR	1.0mm
		L2 PSR	8 cm
		L2 ADR	1.0mm
	GLONASS	L1 PSR	8 cm
		L1 ADR	1.0mm
		L2 PSR	8 cm
		L2 ADR	1.0mm
Physical Description			
Size	71 * 46 * 9.3 mm <sup>3</sup>		
Weight	28g		
Mechanical Drawing			

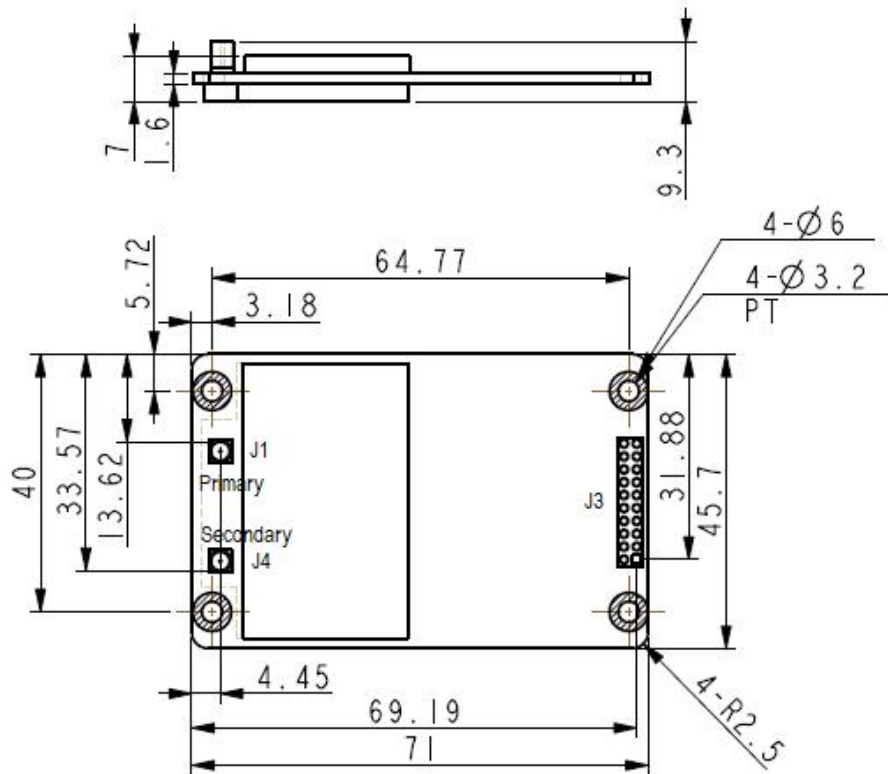

### HEAT SINK POSITION<sup>1</sup>

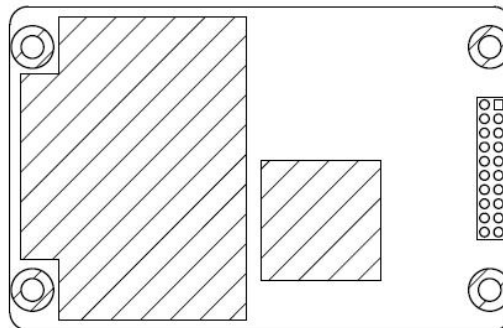

### ENVIRONMENTAL

Operating Temperature	-40C to +85C
Storage Temperature	-55C to +95C
Humidity	MIL-STD-810G, Method 507.5 Procedure II (95%)
Random Vibration	MIL-STD 810G Method 514.6, Category 24 (7.7 g RMS)
Sinusoidal Vibration	IEC 60068-2-6 (5 g)
Bump	ISO 9022-31-06 (25 g)
Shock	Operating: MIL-STD-810G, Method 516.6, Procedure I (40 g) Non-operating: MIL-STD-810G, Method 516.6, Procedure V

	(75 g)
Power Requirement	
Input Voltage	+3.3 +5%/-3% VDC
Allowable Voltage Ripple	100 mV p-p maximum
Power Consumption	2.9W (typical)

Note 1: when BX316D card is assembled in a box, a heat sink must be installed between the hatch area and the metal box, or the thermal performance of the card will be decreased.

## 6.1 Connectors on BX316D Board

There are three connectors on the BX316D board, J1, J3 and J4, see the mechanical drawing in the above table.

1. J1/J4: MMCX jack receptacle, straight
2. J3: 2x10 header, 2 mm pitch (SAMTEC P/N TMM-110-03-G-D)

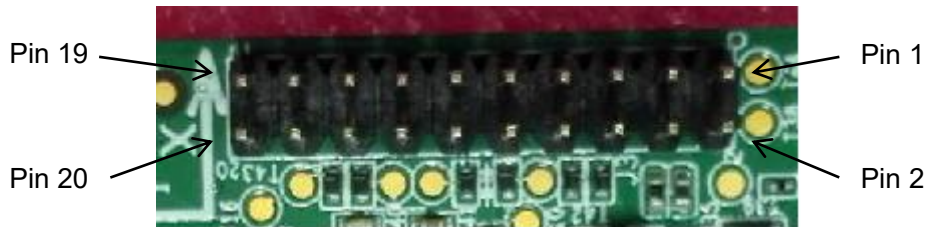

Table 20 Interface Signals Definition

Pin	Signal	TYPE	Description	Comments
1	LNA_PWR	PWR	Antenna power input	Power to antenna, should be input 5VDC.
2	3V3	PWR	Power to the board	3.3V +5%/-3%
3	USB_D-	IO	USB data (-)	One-half of a differential pair (pins 3 and 4). Match lengths and route as a 90 Ω differential pair if USB is required
4	USB_D+	IO	USB data (+)	
5	/RESETIN	I	Reset input t	Active low reset
6	USERVARF	IO	Variable frequency	

			output	
7	EVENT2	IO	Event 2 Input	
8	N.C			
9	EVENT1	IO	Event1 input	Has a 10K pull-up resistor on card.
10	GND	PWR	Signal and power ground	
11	TXD1	O	COM1 transmit data	LVTTTL level, the max band rate is 921600 bps.
12	RXD1	I	COM1 receive data	
13	GND	PWR	Signal and power ground	
14	TXD2	O	COM2 transmit data	LVTTTL level, the max band rate is 921600 bps.
15	RXD2	I	COM2 receive data	
16	GND	PWR	Signal and power ground	
17	PV	O	Position valid indicator	High: when RTK solution is got. Low: other position types.
18	GND	PWR	Signal and power ground	
19	PPS	O	Pulse per second output,	This pin has an internal 50 ohm line driver. Route as a 50 $\Omega$ single-ended trace
20	N.C			

Refer to section 4.2 if interface board is designed.

## APPENDIX D

### 7. BX306 Enclosure Technical Specifications

Table 21 BX306 Enclosure Performance

GNSS Performance		
Position Accuracy	Single positioning	1.5m RMS (Horizontal)
		3.0m RMS (Vertical)
	RTK Positioning	10mm+1ppm (Horizontal)
		15mm+1ppm (Vertical)
Time to First Fix	Cold Start: <50s Warm Start: <30s	
Reacquisition	0.5 s L1 (typical) 1.0 s L2 (typical)	
Data Rate	Measurements	20Hz
	Position	5Hz
Time Accuracy	20ns RMS	
Velocity Accuracy	0.03m/s RMS	
Measurement Precision	Refer to BX306 board in chapter 4.	
Physical Description		
Size	102.5 * 57 * 24.5 mm <sup>3</sup>	
Weight	150g	
Mechanical Drawing		

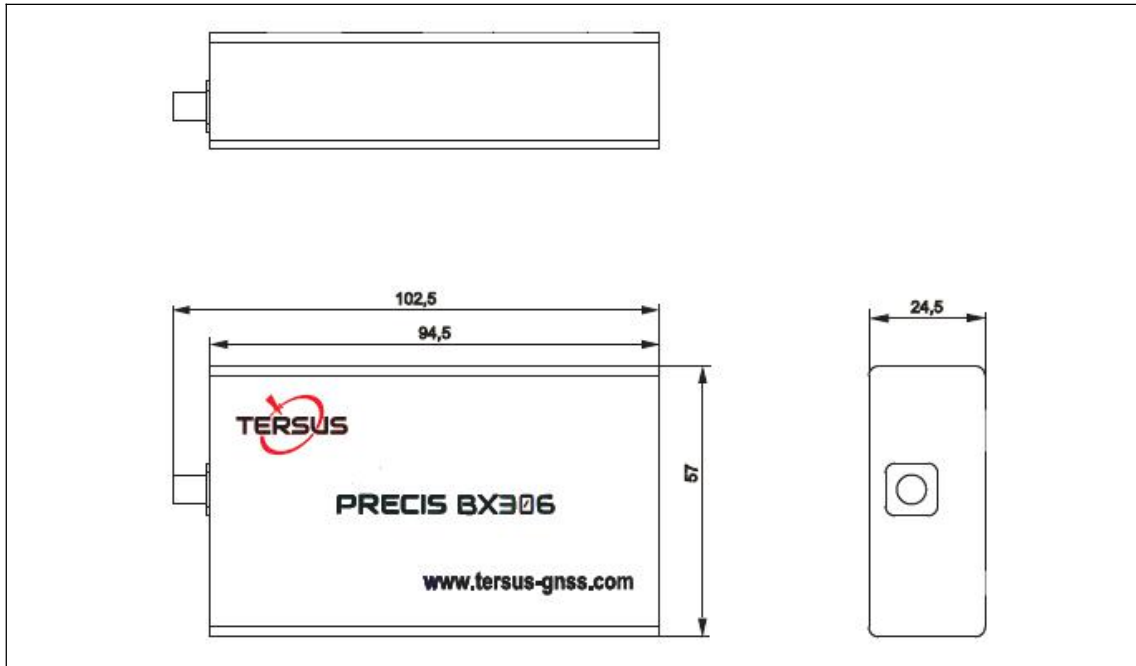

ENVIRONMENTAL	
Operating Temperature	-40C to +85C
Storage Temperature	-55C to +95C
Humidity	MIL-STD-810G, Method 507.5 Procedure II (95%)
Random Vibration	MIL-STD 810G Method 514.6, Category 24 (7.7 g RMS)
Sinusoidal Vibration	IEC 60068-2-6 (5 g)
Bump	ISO 9022-31-06 (25 g)
Shock	Operating: MIL-STD-810G, Method 516.6, Procedure I (40 g) Non-operating: MIL-STD-810G, Method 516.6, Procedure V (75 g)
Power Requirement	
Voltage	+5 – 12 VDC
Power Consumption	3.2W (typical)

## 7.1 20-Pin Cable

A 20-pin cable is provided with the BX306 enclosure.



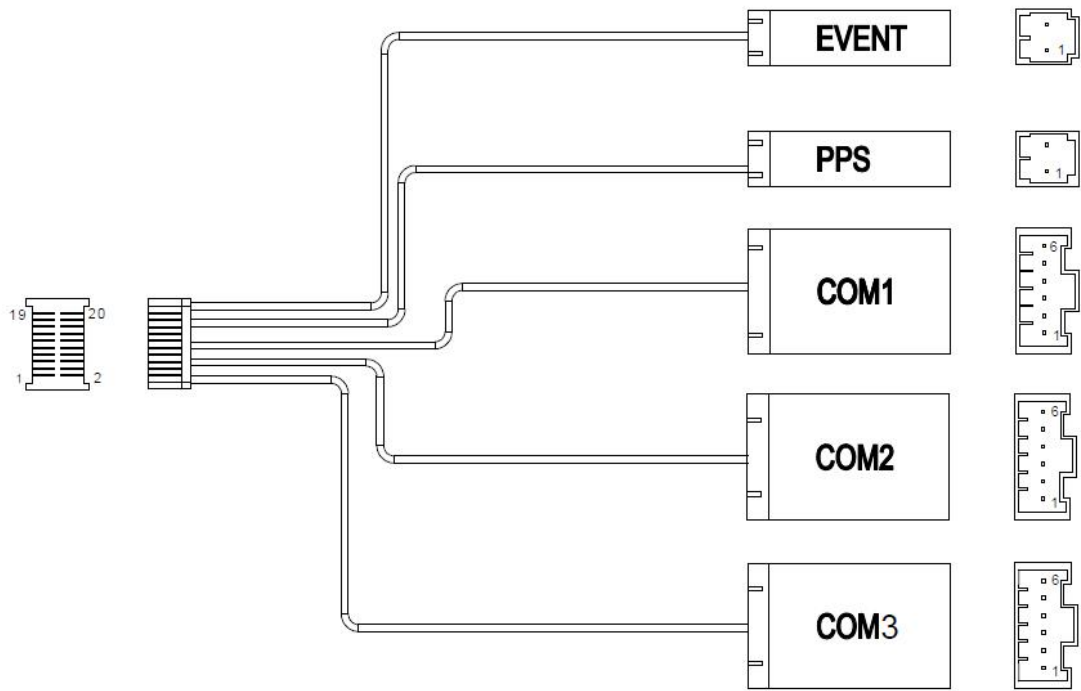

Figure 23 Outline of the 20-pin Cable

The 20-pin connector of the cable is Mouser's DF50S-20DS-1L or equivalent, the connectors at the other side of the cable are 3pcs Mouser's 7980DF1EA-6EP-2.5C and 2pcs 7980DF1EA-2EP-2.5C:

Table 22 Pin Definition of the 20-pin Cable

No.	Signal Definition	COM1	COM2	COM3	EVENT	PPS
1	GND	Pin 6				
2	N.C					
3	COM1_TX	Pin 2				
4	COM2_RX		Pin 3			
5	COM1_RX	Pin 3				
6	COM2_TX		Pin 2			
7	3.3V	Pin 1				
8	3.3V					
9	PPS					Pin 1
10	COM2_SCL		Pin 4			
11	EVENT1				Pin 1	
12	COM2_SDA		Pin 5			
13	GND			Pin 6		
14	GND		Pin 6			
15	COM3_TX			Pin 2		
16	GND					Pin 2
17	COM3_RX			Pin 3		
18	GND				Pin 2	
19	3.3V		Pin 1	Pin 1		
20	N.C					

## APPENDIX E

### 8. BX316 Enclosure Technical Specifications

Table 23 BX316 Enclosure Performance

GNSS Performance			
Position Accuracy	Single positioning	1.5m RMS (Horizontal)	
		3.0m RMS (Vertical)	
	RTK Positioning	10mm+1ppm (Horizontal)	
		15mm+1ppm (Vertical)	
Heading accuracy	0.2 degree (1m baseline)		
Time to First Fix	Cold Start: <50s Warm Start: <30s		
Reacquisition	0.5 s L1 (typical) 1.0 s L2 (typical)		
Data Rate	Measurements	20Hz	
	Position	5Hz	
Time Accuracy	20ns RMS		
Velocity Accuracy	0.03m/s RMS		
Measurement Precision	GPS	L1 PSR	6 cm
		L1 ADR	1.0mm
		L2 PSR	8 cm
		L2 ADR	1.2mm
	BDS	L1 PSR	6 cm
		L1 ADR	1.0mm
		L2 PSR	8 cm
		L2 ADR	1.0mm
	GLONASS	L1 PSR	8 cm
		L1 ADR	1.0mm
		L2 PSR	8 cm
		L2 ADR	1.0mm
Physical Description			
Size	118 * 57 * 24.5 mm <sup>3</sup>		
Weight	150g		

Mechanical Drawing	
ENVIRONMENTAL	
Operating Temperature	-40C to +85C
Storage Temperature	-55C to +95C
Humidity	MIL-STD-810G, Method 507.5 Procedure II (95%)
Random Vibration	MIL-STD 810G Method 514.6, Category 24 (7.7 g RMS)
Sinusoidal Vibration	IEC 60068-2-6 (5 g)
Bump	ISO 9022-31-06 (25 g)
Shock	Operating: MIL-STD-810G, Method 516.6, Procedure I (40 g) Non-operating: MIL-STD-810G, Method 516.6, Procedure V (75 g)
Power Requirement	
Voltage	+5 – 12 VDC
Power Consumption	3.2W (typical)

### 8.1 40-Pin Cable

A 40-pin cable is provided with the BX316/BX316R enclosure.

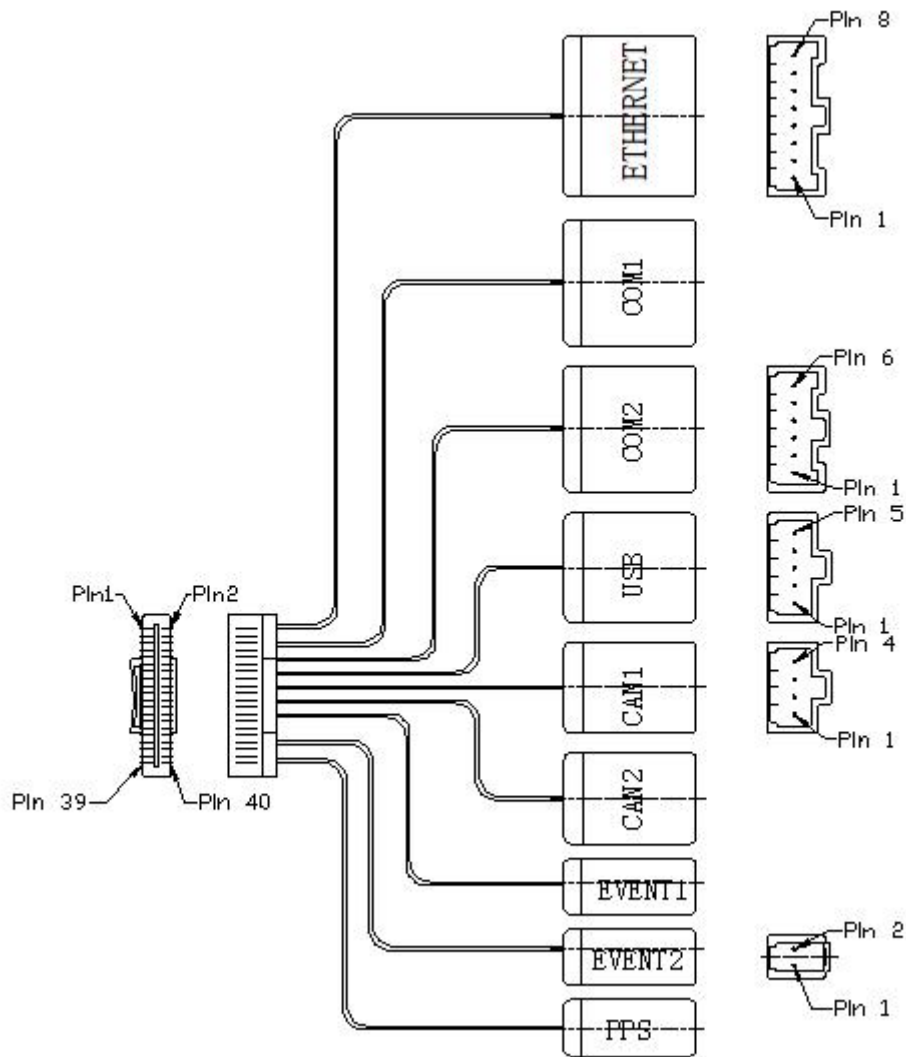

Figure 24 Outline of the 40-pin Cable

The 40-pin connector of the cable is Mouser's DF50S-40DS-1L or equivalent, the connectors at the other side of the cable are 3pcs Mouser's 7980DF1EA-6EP-2.5C and 2pcs 7980DF1EA-2EP-2.5C:

Table 24 Pin Definition of the 40-pin Cable

Pin No.	Signal Name	Ethernet	COM1	COM2	USB	CAN1	CAN2	Event1	Event2	PPS
1	N.C									
2	TD1+	1								
3	EVENT2								1	

4	TD1-	2								
5	GND							2		
6	LED0	6								
7	RD1+	4								
8	LED1	7								
9	RD1-	5								
10	GND	8								
11	GND	3								
12	GND						2			
13	N.C									
14	EVENT1						1			
15	GND								2	
16	PPS								1	
17	GND			6						
18	COM1_RXD		3							
19	SDA			5						
20	COM1_TXD		2							
21	SCL			4						
22	GND		6							
23	COM2_RXD			3						
24	3.3V		1							
25	COM2_TXD			2						
26	3.3V					1				
27	3.3V			1						
28	CANH1_TXD					2				
29	N.C									
30	CANH1_RXD					3				
31	OTG_5V				1					
32	GND					4				
33	USB_DM				2					
34	3.3V						1			
35	USB_DP				3					
36	CANH2_TXD						2			
37	USB_ID				4					
38	CANH2_RXD						3			
39	GND				5					
40	GND						4			

## APPENDIX F

### 9. BX316R Enclosure Technical Specifications

Table 25 BX316R Enclosure Performance

GNSS Performance			
Position Accuracy	Single positioning	1.5m RMS (Horizontal)	
		3.0m RMC (Vertical)	
Time to First Fix	Cold Start: <50s Warm Start: <30s		
Reacquisition	0.5 s L1 (typical) 1.0 s L2 (typical)		
Data Rate	Measurements	20Hz	
	Position	5Hz	
Time Accuracy	20ns RMS		
Velocity Accuracy	0.03m/s RMS		
Measurement Precision	GPS	L1 PSR	6 cm
		L1 ADR	1.0mm
		L2 PSR	8 cm
		L2 ADR	1.2mm
	BDS	L1 PSR	6 cm
		L1 ADR	1.0mm
		L2 PSR	8 cm
		L2 ADR	1.0mm
	GLONASS	L1 PSR	8 cm
		L1 ADR	1.0mm
		L2 PSR	8 cm
		L2 ADR	1.0mm
Physical Description			
Size	118 * 57 * 24.5 mm <sup>3</sup>		
Weight	150g		
Mechanical Drawing			

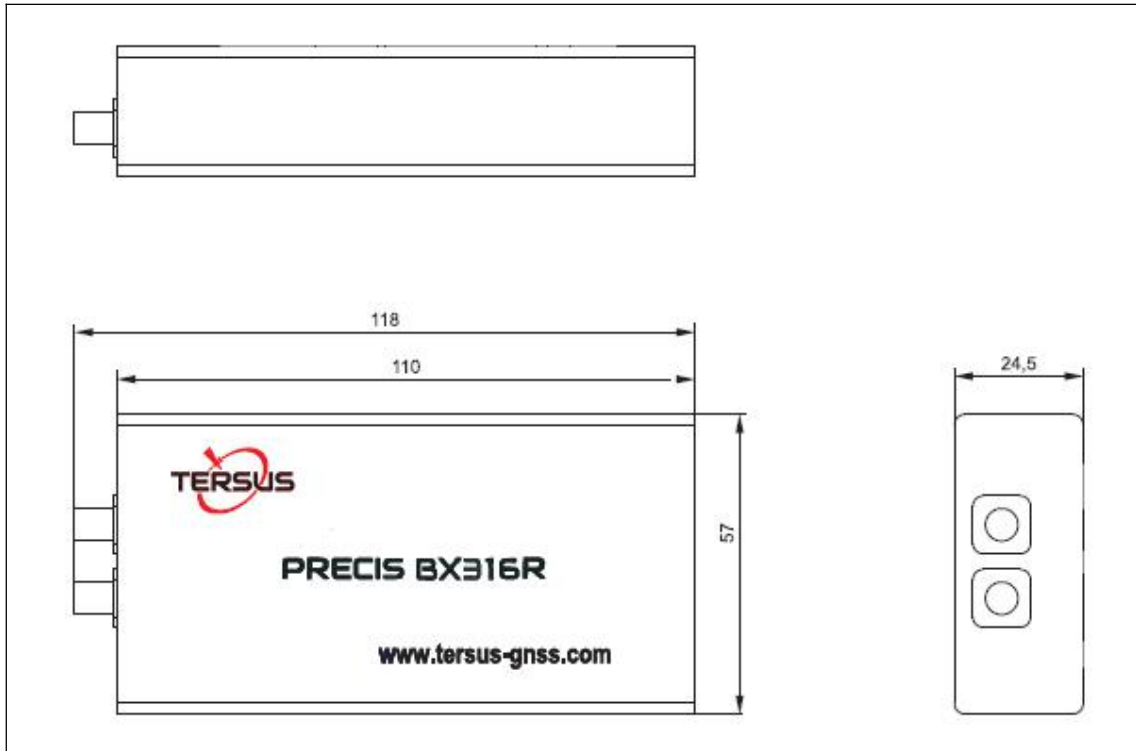

ENVIRONMENTAL	
Operating Temperature	-40C to +85C
Storage Temperature	-55C to +95C
Humidity	MIL-STD-810G, Method 507.5 Procedure II (95%)
Random Vibration	MIL-STD 810G Method 514.6, Category 24 (7.7 g RMS)
Sinusoidal Vibration	IEC 60068-2-6 (5 g)
Bump	ISO 9022-31-06 (25 g)
Shock	Operating: MIL-STD-810G, Method 516.6, Procedure I (40 g) Non-operating: MIL-STD-810G, Method 516.6, Procedure V (75 g)
Power Requirement	
Voltage	+5 – 12 VDC
Power Consumption	3.2W (typical)



## APPENDIX G

### 10. Typical Application

#### 10.1. Uninstall the Cable from BX306 Enclosure

The 20-pin/40-pin cable is self-locking, the connection will be reliable after the cable is installed. The following gives how to uninstall the cable from the receiver with the 20-pin cable as an example.

After installed, the cable is like this:



Figure 25 Cable is Assembled

Insert the gap with a flathead screwdriver, then pull out the cable.



Figure 26 Uninstall the Cable

## 10.2. Connect BX306 to Pixhawk

A specific Pixhawk cable is used to connect the BX306 receiver to Pixhawk's GPS port.



Figure 27 Cable between Pixhawk and BX306

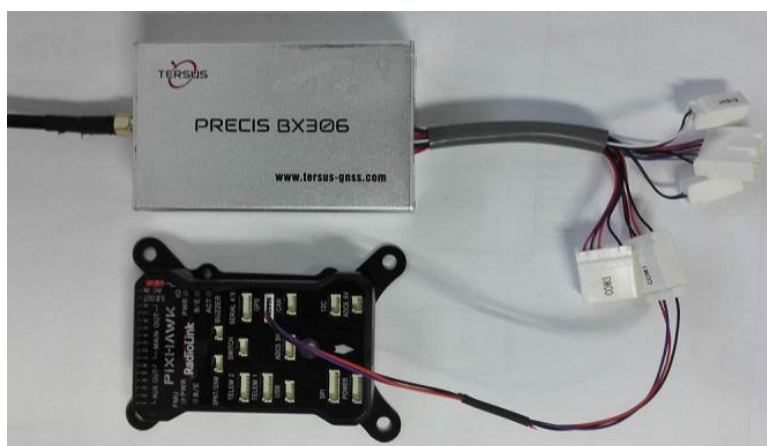

Figure 28 Outline of BX306 Connected to Pixhawk

Table 26 Configure for Pixhawk

1. Refer to Figure 28 to create hardware installation with Pixhawk.
2. Power on the BX306 receiver.
3. The configure for the BX306 receiver:
COM COM1 115200 //Configure the baud rate, must be the same as the GPS port.
NMEATALKER GP //All NMEA will have GP talker
LOG COM1 GPGGA ONTIME 0.2 //Output GPGGA at 5Hz
LOG COM1 GPVTG ONTIME 0.2 //Output GPVTG at 5Hz
LOG COM1 GPRMC ONTIME 0.2 //Output GPRMC at 5Hz
SAVECONFIG //Save the configure above

Run Mission Planner software and create communication with the Pixhawk. The GPS data from the BX306 is recognized by Mission Planner if the GPS status becomes '3D Fix' (see Figure 29).



Figure 29 Pixhawk Get Position from BX306

To get the cm-level position, RTK corrections must be transmitted to the BX306 enclosure, which is connected to the Pixhawk. Two methods are used to transmit RTK corrections:

- 1) The BX306 on the UAV is connected to a radio, which is used to receive the RTK corrections from a base on ground, refer to section 11.3.
- 2) If a data link between the UAV and the on-ground laptop has been created, then a base BX306 can be installed on ground and COM1 of the BX306 is connected to the laptop.

Table 27 Main Steps to Create RTK Base for Pixhawk

1. The configure for the base BX306 receiver:

```

FIX POSITION LATITUDE LONGITUDE HEIGHT //Fix the base's position
LOG COM1 RTCM1005 ONTIME 1 // Output the base's position
LOG COM1 RTCM1077 ONTIME 1 //Output GPS L1/L2 raw data
LOG COM1 RTCM1087 ONTIME 1 //Output GLONASS L1/L2 raw data
LOG COM1 RTCM1127 ONTIME 1 //Output BDS B1/B2 raw data
    
```

2. Communicate Mission Planner with the Pixhawk, open the Initial Setup -> Optional Hardware -> RTK GPS Inject screen

3. Select the serial port and baud rate, press Connect, the following figure will show the RTK corrections from the base BX306 are received.

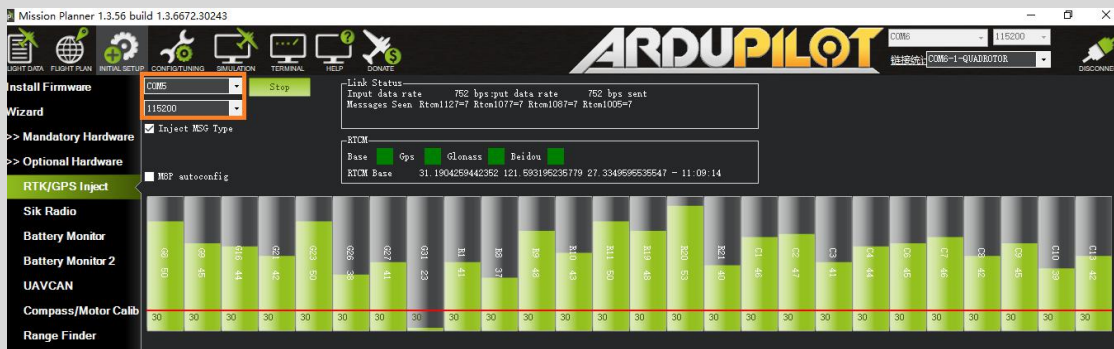

4. After the rover BX306 is outputting RTK solution to the Pixhawk, the GPS status will change from '3D fix' to 'rtk Fixed'.

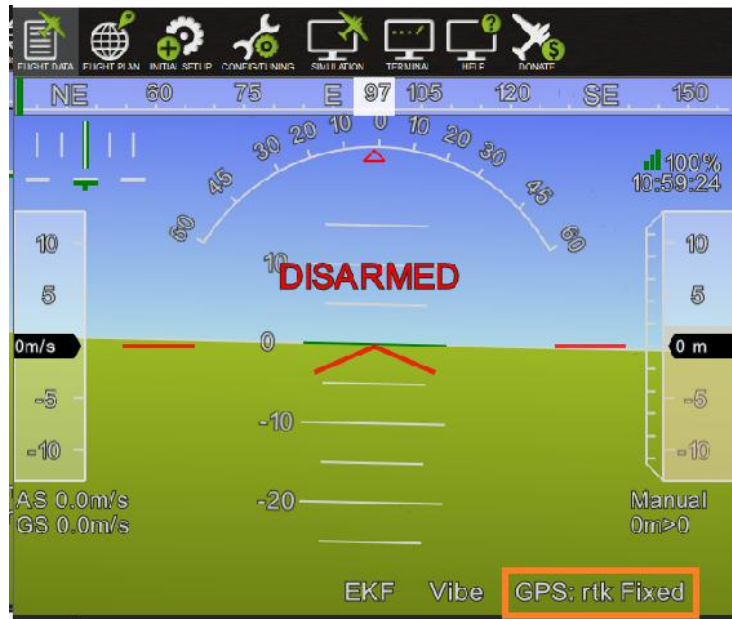

### 10.3. Connect BX306 to a Radio

An external radio can be used to receive RTK corrections, transmit RTK corrections or transmit GNSS PVT solutions. BX306 receiver can connect to any radio which has a LVTTTL serial interface. Tersus is providing a transfer cable between LVTTTL and RS-232 level, see Figure 30, contact [support@tersus-gnss.com](mailto:support@tersus-gnss.com) for more.



Figure 30 Transfer Cable



Two radios must have the same channel and the same protocol before they can communicate each other.



It's highly recommended that the radio at the base side and the one at the rover side are from one company. Compatibility and reliability problems may happen if two radios are from different companies, although they're compatible.

Figure 31 shows a BX306 receiver connected to Tersus RS05R radio, see more about this radio in <https://www.tersus-gnss.com/product/radio-rs05r>.



Figure 31 Outline of BX306 Connected to RS05R Radio

### 10.3.1 Radio to Receive RTK Corrections

- 1) Connect an antenna to the BX306.
- 2) Connect the COM1 of the BX306 to a laptop.
- 3) Connect the COM2 of the BX306 to the radio.
  
- 4) Power on the BX306.
- 5) Connect to an antenna to RS05R radio and power on it.
- 6) Run Tersus GNSS Center to communicate with the BX306 enclosure.
  
- 7) Ensure COM2 has the same baud rate as the radio's serial port.
- 8) Check the position type of the BX306 in Tersus GNSS Center.

### 10.3.2 Radio to Transmit RTK Corrections

Follow step 1) to 6) in section 0.

- 7) Input the following commands/loggings to the BX306 enclosure in Tersus GNSS Center:

```

FIX POSITION LATITUDE LONGITUDE HEIGHT //Fix the base
LOG COM2 RTCM1074 ONTIME 1 //Output GPS raw measurements
LOG COM2 RTCM1084 ONTIME 1 //Output GLONASS raw measurements
LOG COM2 RTCM1124 ONTIME 1 //Output BDS raw measurements
SAVECONFIG //Save the configure above

```



### 10.3.3 Radio to Transmit the PVT Solutions

Follow step 1) to 6) in section 0.

7) Input the loggings interested in Tersus GNSS Center, for example:

```
LOG COM2 GPGGA ONTIME 1      //Output GPGGA
LOG COM2 TIMEB ONTIME 1      //Output time
.....
SAVECONFIG                    //Save the configure above
```

### 10.4. Save Data to an External Datalogger

Tersus is providing an external datalogger DL207, see Figure 32. DL207 can support up to 32GB SD card with FAT32 format. See <https://www.tersus-gnss.com/product/external-data-logger-dl207> for more about it.



Figure 32 Datalogger DL207



Figure 33 Outline of BX306 Connected to DL207

- 1) Install a SD card to the DL207.
- 2) Connect an antenna to the BX306.
- 3) Connect COM2 of the BX306 to a laptop.
- 4) Power on the BX306.
- 5) Run Tersus GNSS Center to communicate with the COM2 of BX306.
- 6) Input all the data needed to save on the DL207, for example:

```
LOG COM1 RANGE B ONTIME 1           //Save raw measurements
LOG COM1 GPGGA ONTIEM 1             //Save GPGGA info
LOG COM1 GPSEPHEMB ONTIME 30        //Save the GPS ephemeris
.....
SAVECONFIG                           //Save the configure above
```

- 7) Power off the BX306, connect the DL207 to the COM1 port of the BX306.
- 8) Power on the BX306, the data will be saved on the SD card.
- 9) Power off the BX306 after the data collection is finished.
- 10) Uninstall the SD card from the DL207, copy the file on the SD card to your laptop with a SD reader.

## 10.5. Connect BX306 to an External Bluetooth

Tersus is providing an external Bluetooth BT120, as well as the cable for the BX306 receiver. For more details about the Bluetooth module, please go to <https://www.tersius-gnss.com/product/bluetooth-bt120>



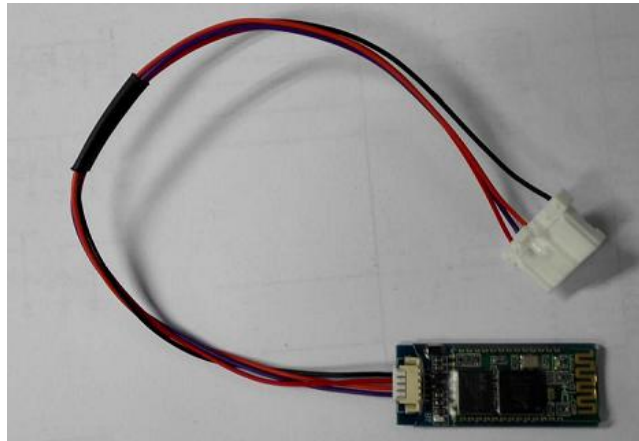

Figure 34 BT120 and the Cable



Figure 35 Outline of BX306 Connected to BT120

The function of Bluetooth module is to communicate the BX306 enclosure with other Bluetooth device.



BT120 can only be paired with an Android phone or tablet; it can't be paired with an iPhone.

### 10.5.1 Communicate with NTRIP Client App.

- 1) Connect a BT120 to COM1 of the BX306 enclosure.
- 2) Connect COM2 of the BX306 to a laptop.
- 3) Connect an antenna to the BX306, and power on it.
- 4) Pair your Smartphone with the BT120. The default ID of BT120 is HB-02, the pair password is 1234, after paired, HB-02 will be listed in the paired devices.

- 5) Run NTRIP Client App in the Smartphone, press the Settings button to go to the Settings page:

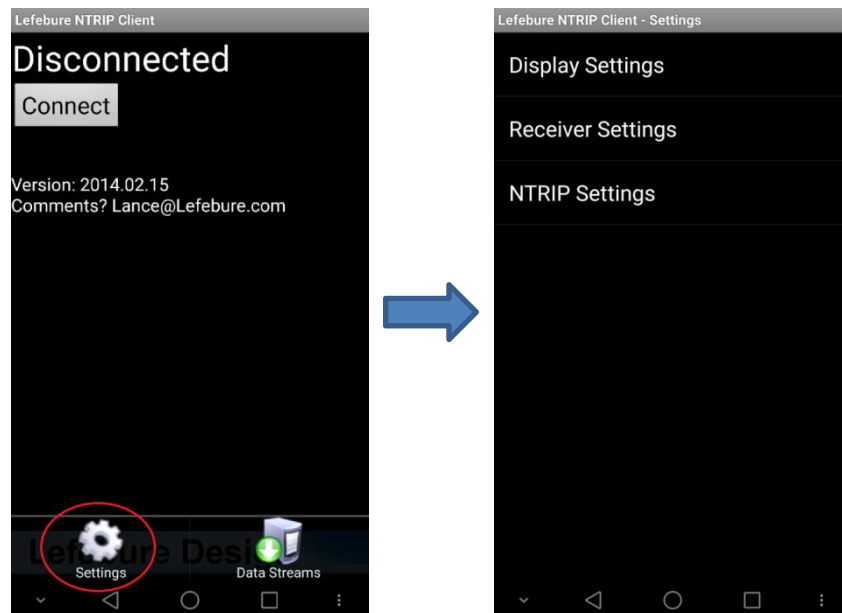

- 6) In the 'Receiver Settings', input the Bluetooth name which has been paired in step 3), all other options can keep the default.
- 7) In the 'NTRIP Settings', all the upper six fields (Network Protocol, Caster IP, Caster Port, Username, Password and Data Stream) are mandatory, please input them with the info you've gotten from the NTRIP service provider. If needed by the caster, input the draft location of the receiver in the three fields below.

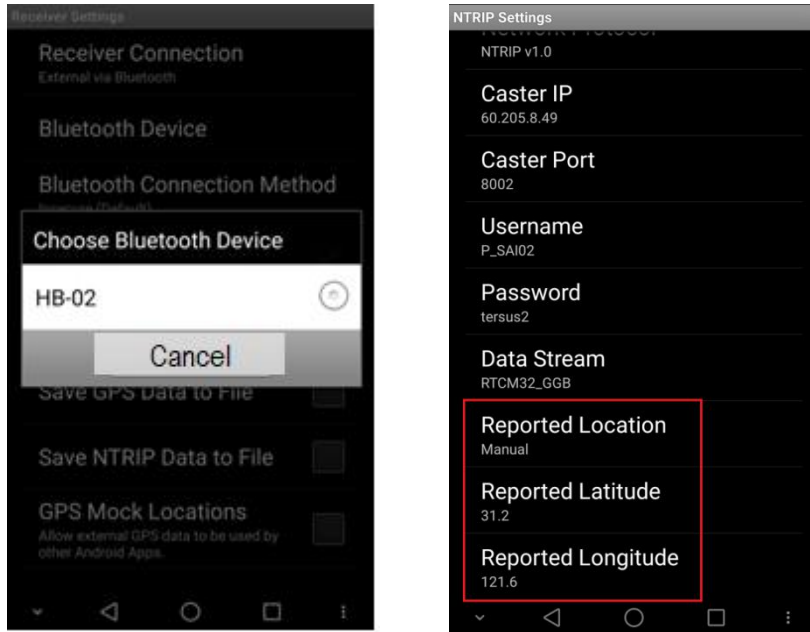

- 8) Go back to the first page of NTRIP and press 'CONNECT' button, if everything is OK, you will see the following page, which shows RTK corrections are being received and forwarded to the receiver via the Bluetooth.

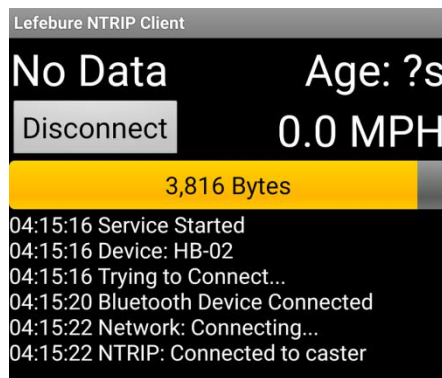

- 9) Check the position type of the BX306.

## 10.6 Communicate with STRSVR Tool

- 1) Power on the BX306 enclosure, connect COM1 and COM2 to the computer. COM1 is communicating with Tersus Center, COM2 is to receive RTK corrections from a NTRIP caster.
- 2) Run RTKLIB -> STRSVR, select serial for output type. And press the option button for serial port COM2 and configure it.

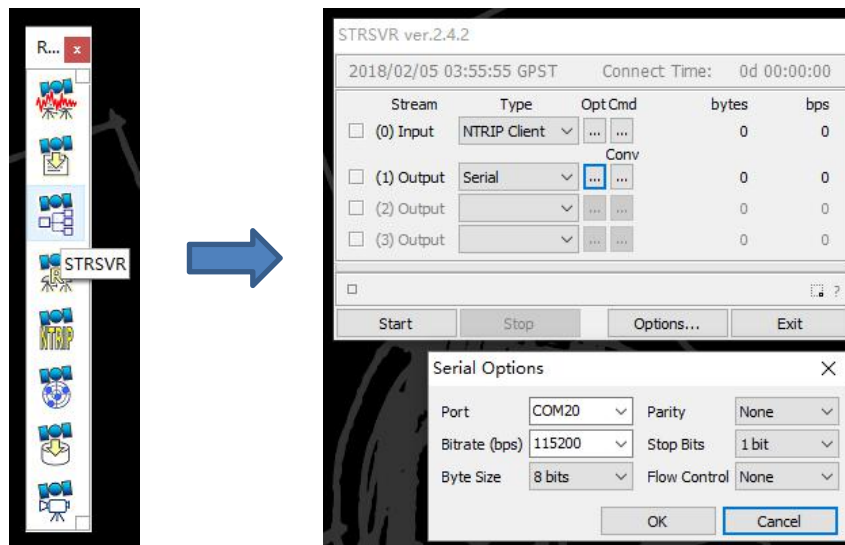

- 3) Select NTRIP client for input type, press the Opt button for NTRIP, fill all the five fields for NTRIP configure.
- 4) If needed, draft position of the receiver is input, see the following figure.

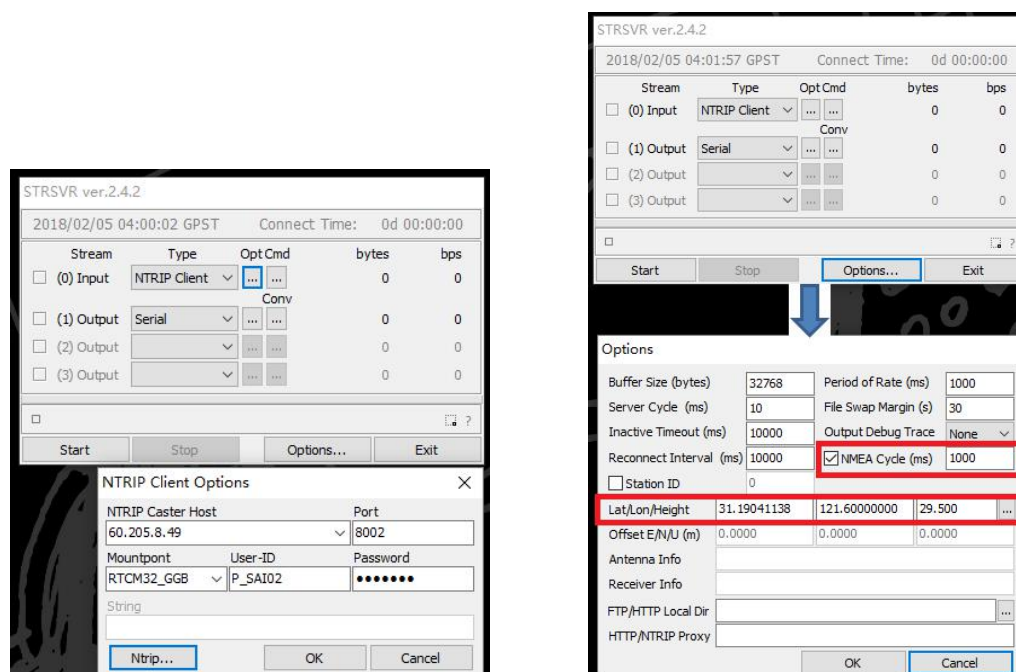

- 5) Go back to the main page, and press Start button. If everything is OK the following page will be shown. The input and output data will increase with time. And you can check the position type of the receiver in Tersus Center.

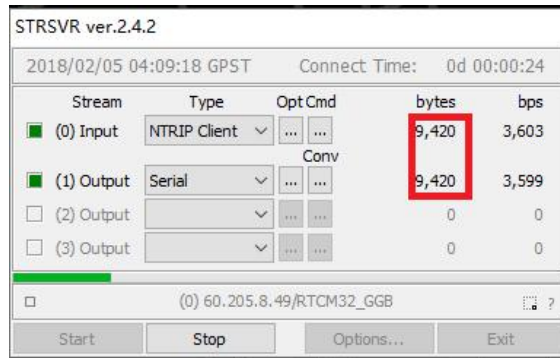

## 10.7 Data Collection on Internal eMMC Card

All the BX cards/enclosures are providing up to 4GB internal eMMC card, which brings convenience for data collection.



Before data collection, please ensure enough space is available on the internal eMMC card, refer to Table 30 to delete files on the internal eMMC card if needed.



The size of the logging:

LOG FILE RANGE B ONTIME 1 (about 110KByte/min if 20 satellites are tracked, about 165KByte/min if 30 satellites are tracked)

If the collection frequency is increased, the data size will be increased proportionately.



Rules for the file name & update time in the external SD card:

- 1) Name: file name is the 00..00xx..xx.dat, totally 8 digits, in which xxxx is the working time (seconds/100) of the receiver. For example, the receiver has worked 500 hours 40min,  $(500 \times 3600 + 40 \times 60) / 100 = 18024$ , the file name will be 00018024.dat.
- 2) Update time: if the receiver hasn't gotten the GNSS time, the update time of the files will be 19800000 0:0 (YYYYMMDD HH:MM). If the receiver has gotten the GNSS time, the update time will be the UTC time.

Two modes can be selected for data collection: manually (default) and automatically.

If you want to save the loggings manually after the board is power on, please follow the steps in Table 28 to configure the BX306 enclosure:

Table 28 Save Data on eMMC Card Manually

1. STORETYPE EMMC //the data will be saved on the internal EMMC card
2. Input all the loggings to be saved, for example: LOG FILE GPGGA ONTIME 1 //save GPGGA loggings LOG FILE PASSUSBB ONNEW //save the data from the USB port LOG FILE RANGE B ONTIME 1 //save raw measurements
3. SAVECONFIG //save the configure above
4. LOGFILE OPEN //open the file to start data collection
5. LOGFILE CLOSE //close the file to stop data collection

If you want to save the loggings automatically after the board is power on, please follow the steps in Table 29:

Table 29 Save Data on eMMC Card Automatically

1. STORETYPE EMMC //(the data will be saved on the internal eMMC card
2. Input all the loggings to be saved, for example: LOG FILE GPGGA ONTIME 1 //save GPGGA info LOG FILE PASSCOM1B ONNEW //save the data from the COM1 LOG FILE RANGE B ONTIME 1 //save raw measurements
3. LOGFILE AUTO //configure auto data collection
4. SAVECONFIG //save the configure above
5. Power cycle the board and data collection start.
6. LOGFILE CLOSE //close the file after data collection is finished

The last step is recommended although it's not mandatory. If power is off during the file collection, the data collected in the last second may not be saved.

	The data collection will not be executed without a power cycle.
---	---

## 10.8 Download Files from Internal eMMC Card

The files saved on the internal eMMC card can be copied to the computer via a serial port.

If files are downloaded from a BX316 or a BX316R enclosure, the USB port is recommended. A specific USB cable is used to connect the USB port to the computer, refer to Figure 38 and Figure 24.

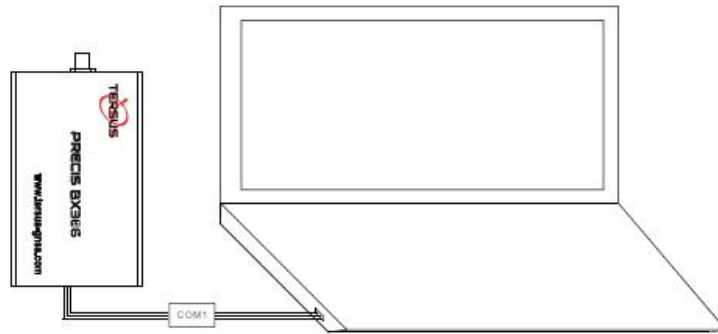

Figure 36 Download Files from eMMC Card with a Serial Port

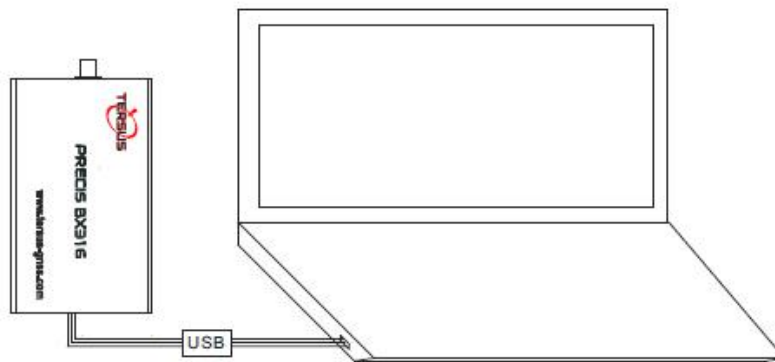

Figure 37 Download Files from eMMC Card with an USB Port



Figure 38 USB Cable

After the USB adapter or the USB cable is installed into the computer, it will be mapped to a serial port, refer to 2.2 USB Adapter.

Table 30 Detailed Steps to Download Files from eMMC Card

1. Refer to Figure 36 and Figure 37 to create connection between a BX306/BX316 receiver and a computer.

2. Run the TersusDownload, the following page will be shown:

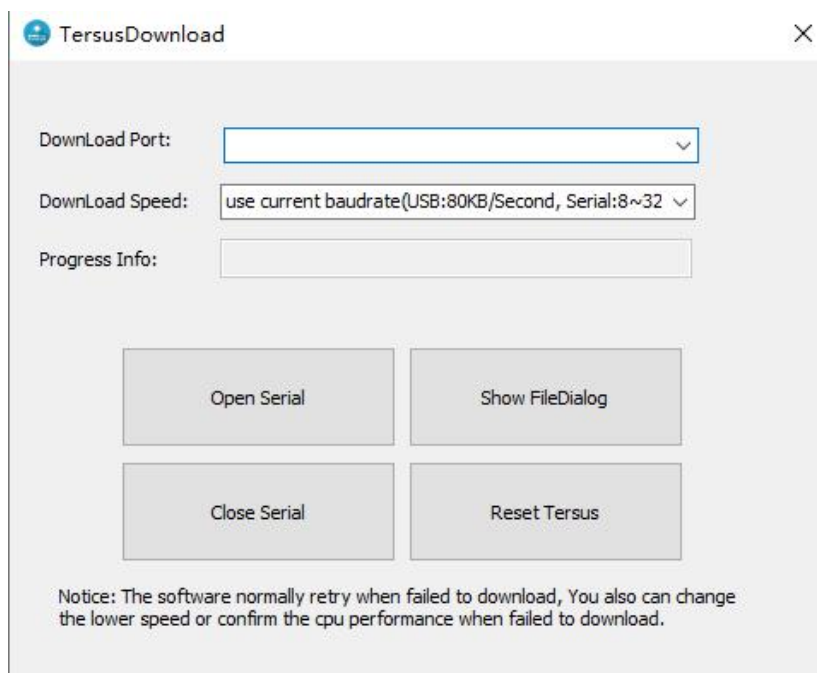

3. Choose the serial port to communicate with the receiver.

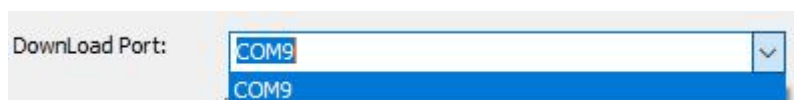

4. In the Download Speed menu, if the serial port is used, select the download speed. If the USB is used, choose the USB port.

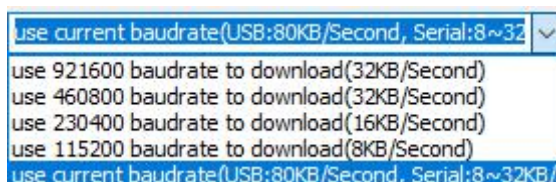

5. Press the Open Serial button, all the files on the eMMC card will be read and



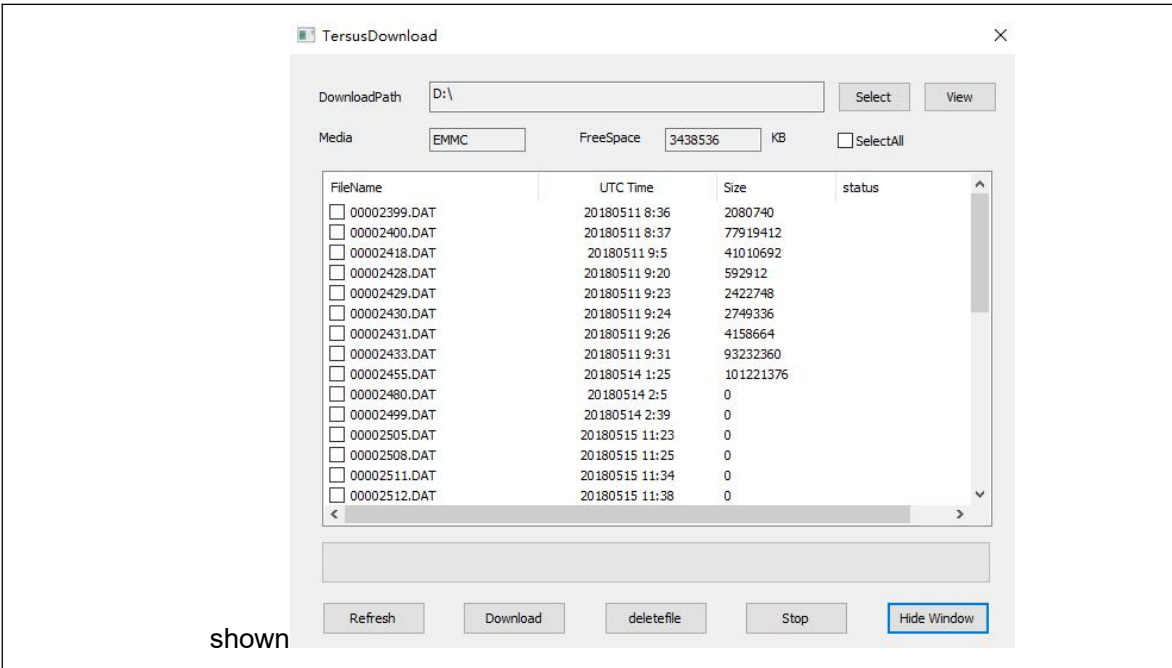

6. Input the DownloadPath and select the files to be downloaded, press Download button to start downloading.

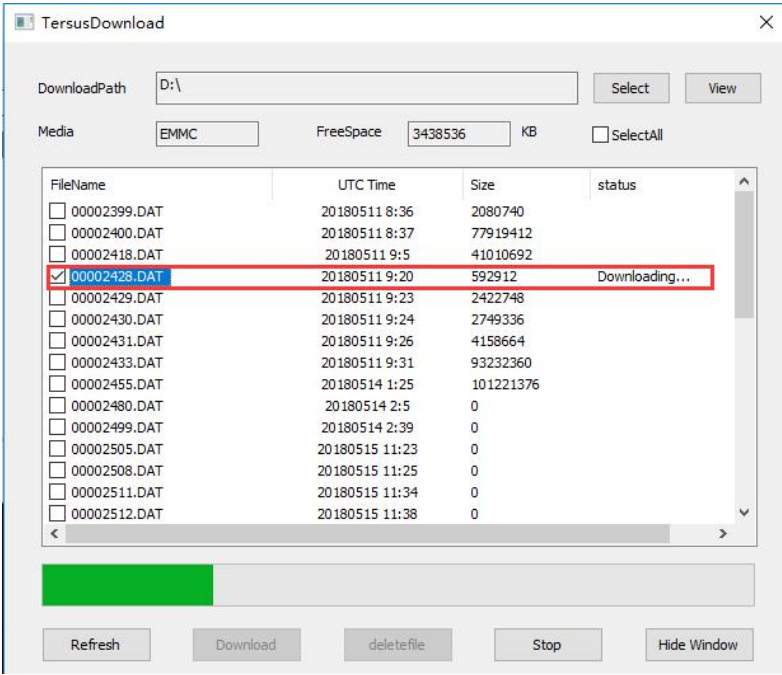

7. After the downloading is finished, check the files in the directory.



## 11 Terminology

---

ASCII	American Standard Code for Information Interchange
CMR	Compact Measurement Record
DC	Direct Current
ESD	Electro Static Discharge
ECEF	Earth Center Earth Fixed
GLONASS	GLObal NAVigation Satellite System
GNSS	Global Navigation Satellite System
GPS	Global Positioning System
IF	Intermediate Frequency
IMU	Inertial Measurement Unit
IO	Input/Output
LED	Light Emitting Diode
LNA	Low Noise Amplifier
MPU	Micro Processing Unit
NMEA	National Marine Electronics Association
PC	Personal Computer
PPS	Pulse Per Second
RF	Radio Frequency
RINEX	Receiver Independent Exchange format
RMS	Root Mean Squares
RTK	Real-Time Kinematic
RTCM	Radio Technical Commission for Maritime Services
SMA	Sub-Miniature-A interface
TTF	Time to First Fix
TTL	Transistor-Transistor Logic level
UART	Universal Asynchronous Receiver/Transmitter
USB	Universal Serial BUS
WGS84	World Geodetic System 1984